

Model 8010 High Power Device Test Fixture

User's Manual

8010-900-01 Rev. A / February 2012

Model 8010

High Power Device Test Fixture

User's Manual

© 2012, Keithley Instruments, Inc.

Cleveland, Ohio, U.S.A.

All rights reserved.

Any unauthorized reproduction, photocopy, or use the information herein, in whole or in part, without the prior written approval of Keithley Instruments, Inc. is strictly prohibited.

All Keithley Instruments product names are trademarks or registered trademarks of Keithley Instruments, Inc. Other brand names are trademarks or registered trademarks of their respective holders.

The Lua 5.0 software and associated documentation files are copyright © 1994-2008, Tecgraf, PUC-Rio. Terms of license for the Lua software and associated documentation can be accessed at the [Lua licensing site \(http://www.lua.org/license.html\)](http://www.lua.org/license.html).

Document number: 8010-900-01 Rev. A / February 2012

The following safety precautions should be observed before using this product and any associated instrumentation. Although some instruments and accessories would normally be used with nonhazardous voltages, there are situations where hazardous conditions may be present.

This product is intended for use by qualified personnel who recognize shock hazards and are familiar with the safety precautions required to avoid possible injury. Read and follow all installation, operation, and maintenance information carefully before using the product. Refer to the user documentation for complete product specifications.

If the product is used in a manner not specified, the protection provided by the product warranty may be impaired.

The types of product users are:

Responsible body is the individual or group responsible for the use and maintenance of equipment, for ensuring that the equipment is operated within its specifications and operating limits, and for ensuring that operators are adequately trained.

Operators use the product for its intended function. They must be trained in electrical safety procedures and proper use of the instrument. They must be protected from electric shock and contact with hazardous live circuits.

Maintenance personnel perform routine procedures on the product to keep it operating properly, for example, setting the line voltage or replacing consumable materials. Maintenance procedures are described in the user documentation. The procedures explicitly state if the operator may perform them. Otherwise, they should be performed only by service personnel.

Service personnel are trained to work on live circuits, perform safe installations, and repair products. Only properly trained service personnel may perform installation and service procedures.

Keithley Instruments products are designed for use with electrical signals that are rated Measurement Category I and Measurement Category II, as described in the International Electrotechnical Commission (IEC) Standard IEC 60664. Most measurement, control, and data I/O signals are Measurement Category I and must not be directly connected to mains voltage or to voltage sources with high transient overvoltages. Measurement Category II connections require protection for high transient overvoltages often associated with local AC mains connections. Assume all measurement, control, and data I/O connections are for connection to Category I sources unless otherwise marked or described in the user documentation.

Exercise extreme caution when a shock hazard is present. Lethal voltage may be present on cable connector jacks or test fixtures. The American National Standards Institute (ANSI) states that a shock hazard exists when voltage levels greater than 30 V RMS, 42.4 V peak, or 60 VDC are present. A good safety practice is to expect that hazardous voltage is present in any unknown circuit before measuring.

Operators of this product must be protected from electric shock at all times. The responsible body must ensure that operators are prevented access and/or insulated from every connection point. In some cases, connections must be exposed to potential human contact. Product operators in these circumstances must be trained to protect themselves from the risk of electric shock. If the circuit is capable of operating at or above 1000 V, no conductive part of the circuit may be exposed.

Do not connect switching cards directly to unlimited power circuits. They are intended to be used with impedance-limited sources. NEVER connect switching cards directly to AC mains. When connecting sources to switching cards, install protective devices to limit fault current and voltage to the card.

Before operating an instrument, ensure that the line cord is connected to a properly-grounded power receptacle. Inspect the connecting cables, test leads, and jumpers for possible wear, cracks, or breaks before each use.

When installing equipment where access to the main power cord is restricted, such as rack mounting, a separate main input power disconnect device must be provided in close proximity to the equipment and within easy reach of the operator.

For maximum safety, do not touch the product, test cables, or any other instruments while power is applied to the circuit under test. ALWAYS remove power from the entire test system and discharge any capacitors before: connecting or disconnecting cables or jumpers, installing or removing switching cards, or making internal changes, such as installing or removing jumpers.

Do not touch any object that could provide a current path to the common side of the circuit under test or power line (earth) ground. Always make measurements with dry hands while standing on a dry, insulated surface capable of withstanding the voltage being measured.

The instrument and accessories must be used in accordance with its specifications and operating instructions, or the safety of the equipment may be impaired.

Do not exceed the maximum signal levels of the instruments and accessories, as defined in the specifications and operating information, and as shown on the instrument or test fixture panels, or switching card.

When fuses are used in a product, replace with the same type and rating for continued protection against fire hazard.

Chassis connections must only be used as shield connections for measuring circuits, NOT as safety earth ground connections.

If you are using a test fixture, keep the lid closed while power is applied to the device under test. Safe operation requires the use of a lid interlock.

If a  screw is present, connect it to safety earth ground using the wire recommended in the user documentation.

The  symbol on an instrument means caution, risk of danger. The user should refer to the operating instructions located in the user documentation in all cases where the symbol is marked on the instrument.

The  symbol on an instrument means caution, risk of electric shock. Use standard safety precautions to avoid personal contact with these voltages.

The  symbol on an instrument shows that the surface may be hot. Avoid personal contact to prevent burns.

The  symbol indicates a connection terminal to the equipment frame.

If this  symbol is on a product, it indicates that mercury is present in the display lamp. Please note that the lamp must be properly disposed of according to federal, state, and local laws.

The **WARNING** heading in the user documentation explains dangers that might result in personal injury or death. Always read the associated information very carefully before performing the indicated procedure.

The **CAUTION** heading in the user documentation explains hazards that could damage the instrument. Such damage may invalidate the warranty.

Instrumentation and accessories shall not be connected to humans.

Before performing any maintenance, disconnect the line cord and all test cables.

To maintain protection from electric shock and fire, replacement components in mains circuits — including the power transformer, test leads, and input jacks — must be purchased from Keithley Instruments. Standard fuses with applicable national safety approvals may be used if the rating and type are the same. Other components that are not safety-related may be purchased from other suppliers as long as they are equivalent to the original component (note that selected parts should be purchased only through Keithley Instruments to maintain accuracy and functionality of the product). If you are unsure about the applicability of a replacement component, call a Keithley Instruments office for information.

To clean an instrument, use a damp cloth or mild, water-based cleaner. Clean the exterior of the instrument only. Do not apply cleaner directly to the instrument or allow liquids to enter or spill on the instrument. Products that consist of a circuit board with no case or chassis (e.g., a data acquisition board for installation into a computer) should never require cleaning if handled according to instructions. If the board becomes contaminated and operation is affected, the board should be returned to the factory for proper cleaning/servicing.

Table of Contents

Welcome	1-1
Welcome	1-1
Extended warranty	1-2
Organization of manual sections.....	1-2
General information.....	1-2
Contact information	1-2
Unpacking and inspection	1-2
Accessories.....	1-2
Characteristics	1-3
Connecting instruments to the Model 8010	2-1
Rear panel overview	2-1
Installing the test boards	2-3
Using the interlock.....	2-5
Connections to the rear panel.....	2-5
Model 2611A and Model 2612A connections	2-6
Model 2635A and Model 2636A connections	2-7
Model 2651A connections.....	2-8
Model 2657A connections.....	2-9
Model 4200 and Model 4210-SMU connections.....	2-10
Model 4200 and Model 4210-SMU with preamplifier connections.....	2-11
Internal protection circuitry	2-12
Using the access port on the Model 8010.....	2-12
Working with devices and instruments	3-1
Safety information	3-1
About the device test boards	3-1
Installing a device in the axial posts.....	3-2
Installing a device in the TO socket	3-3
Using the insulating plug	3-3
Measurement considerations.....	3-4
Suppressing device oscillations	3-6
Using the guard terminal.....	3-8
Off-state characterization of a power MOSFET.....	4-1
Introduction	4-1
Equipment needed.....	4-2
Set up communication.....	4-2
Device connections	4-3
Install the device and make connections	4-6

BVdss measurement.....	4-6
Example program code	4-7
Example program usage	4-8
Idss measurement.....	4-9
Example program code	4-9
Example program usage	4-12
Axial-lead device high current test	5-1
Introduction	5-1
Equipment needed	5-1
Connect the instrument to the Model 8010	5-2
Install the device and make connections	5-3
Set up communication.....	5-3
Example program code	5-4
Example program usage	5-9
On-state characterization of a power MOSFET	6-1
Introduction	6-1
Equipment required for this example	6-2
Connect instruments to the Model 8010	6-2
Install the device and make connections	6-6
Suppressing device oscillations (optional)	6-7
Set up communication.....	6-8
Example program code	6-9
Example program usage	6-16
Troubleshooting FAQs	7-1
Noisy low current measurements.....	7-1
Interlock error message	7-1
Can high-current SMUs be used separately inside the fixture?	7-1
The device is oscillating. How do I correct this?	7-2
Can I use local sense for high-current or lower power SMUs?.....	7-2
Can I operate the test fixture with the lid open?	7-2
Maintenance	8-1
Replacing the boards	8-1
How to clean the Model 8010 Test Fixture	8-1
Connector and socket cleaning.....	8-2
Adjusting the lid hinges	8-2

Next steps..... **9-1**
 Additional information..... 9-1

Index..... **I-1**

In this section:

Welcome	1-1
Extended warranty	1-2
Organization of manual sections	1-2
General information.....	1-2

Welcome

Thank you for choosing a Keithley Instruments product. The Model 8010 High Power Device Test Fixture provides a safe, low noise, complete environment for testing a variety of packaged device types. The replaceable socket module test boards allow for a variety of package types, including the user-supplied socket types.

The Model 8010 allows you to connect one Model 2657A High Power SourceMeter for up to 3 KV testing. You can connect up to two Model 2651A High Power SourceMeters for 15 A DC testing or 50 A or 100 A pulse testing. For lower power terminals, you can connect up to two other SourceMeters, such as Models 2611A, 2612A, 2635A, 2636A, 4200-SMU or 4210-SMU.

The Model 8010 includes:

- Kelvin (remote sense) connections for five instruments
- Guarded pathways for picoampere level measurements even at 3 KV
- An access port for a variety of probes, such as scope or temperature
- Integrated protection circuits to protect Models 2611A, 2612A, 2635A, 2636A, 4200-SMU, and 4210-SMU from high voltage instruments
- Two independent test sockets, one for high current and one for high voltage

The test fixture is fully interlocked, providing safe operation for up to six different instruments. It is declared safe through CE marking and certified through nationally recognized testing laboratories.

The Model 8010 is shipped with two 8010-DTB high power socket module test boards installed. The boards include sockets for TO-247 and axial lead devices.

The high current side of the test fixture can be used with up to 100 amps pulsed, 15 amps DC, 200 VDC. Up to four measurement resources can be connected (two high current, two low power).

The high voltage side of the test fixture can be used with up to 3030 VDC at 120 mA, 200 VDC up to 10 A pulsed. Connections are provided for up to three measurement resources (one high voltage, two low power).

Additional socket module test boards are available. The 8010-CTB Customizable Test Board allows you to add your own socket. The 8010-DTB-220 Test Board is for use with three-terminal TO-220 or TO-247 devices and is limited to 1000 V and the maximum rated current of the test fixture.

Extended warranty

Additional years of warranty coverage are available on many products. These valuable contracts protect you from unbudgeted service expenses and provide additional years of protection at a fraction of the price of a repair. Extended warranties are available on new and existing products. Contact your local Keithley Instruments representative for details.

Organization of manual sections

The first part of this user manual provides general information that helps you set up, install, and make connections to the test fixture.

The sections after the general sections provide information that helps you use the Model 8010 with specific SourceMeter Instruments. This information includes applications that can help you set up your tests.

The last part of the user manual provides maintenance and troubleshooting information. It also provides references to additional resources.

Bookmarks for each section of this manual are provided in the PDF. The manual sections are also listed in the Table of Contents located at the beginning of the manual.

For more information about bookmarks, see Adobe® Acrobat® or Reader® help.

General information

Contact information

If you have any questions after you review the information in this documentation, please contact your local Keithley Instruments representative or call Keithley Instruments corporate headquarters (toll-free inside the U.S. and Canada only) at 1-888-KEITHLEY (1-888-534-8453), or from outside the U.S. at +1-440-248-0400. For worldwide contact numbers, visit the [Keithley Instruments website](http://www.keithley.com) (<http://www.keithley.com>).

Unpacking and inspection

Each Model 8010 was carefully inspected electrically and mechanically before shipment.

After you unpack all items from the shipping carton, check for any obvious signs of physical damage that may have occurred during transit. Report any damage to the shipping agent immediately. Save the original packing carton for possible future shipment.

Accessories

See the "Model 8010 High Power Device Test Fixture Interconnection Reference Guide" for detail on provided accessories.

Characteristics

For indoor use only.

Maximum signal voltage (signal or guard to any signal)	Three-lug high voltage triaxial connector: 3280 V Three-lug standard triaxial connector: 210 V Eight-pin screw terminal connector: 40 V Two-pin high current screw terminal connector: 40 V
Maximum signal current	Three-lug high voltage triaxial connector: 120 mA DC Three-lug standard triaxial connector: 1.5 A DC Eight-pin screw terminal block: 1 A DC Two-pin high-current screw terminal connector: 15 A DC, 50 A pulsed with one SMU; 100 with two SMUs
Maximum combined DC current	15 A DC
Maximum pulse current	100 A at 1% duty cycle for Model 2651A High Power SourceMeter Instrument path 10 A at 1% duty cycle for Series 2600A and Model 4200 paths
Altitude	Maximum 2000 m above sea level
Operating environment	0 °C to 50 °C, 70% relative humidity up to 35 °C. Derate 3% relative humidity/°C, 35 °C to 50 °C
Storage	-25 °C to 65 °C
Safety	Listed to UL61010-1:2004 Conforms to European Union Low Voltage Directive

Connecting instruments to the Model 8010

In this section:

Rear panel overview 2-1
 Installing the test boards 2-3
 Using the interlock..... 2-5
 Connections to the rear panel 2-5
 Using the access port on the Model 8010 2-12

Rear panel overview

Instrument connections are made to the rear panel of the Model 8010.

The rear panel of Model 8010 is shown below. Descriptions of the rear panel connections are provided after the graphic.

Figure 1: Model 8010 rear panel

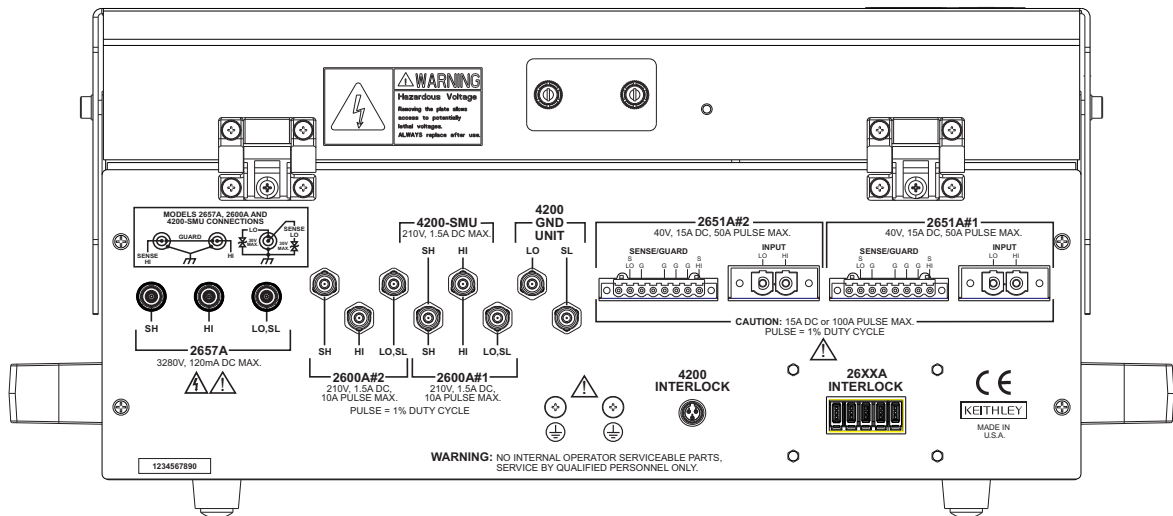

The rear panel options are described on the following pages.

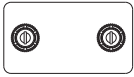

The access port on the lid can be used to bring in connections for external instrumentation.



The Model 2657A connectors provide sense HI, HI, LO, and sense LO input connections for the Model 2657A instruments.

Connections are as follows:

- SH = Sense HI
- HI = HI
- LO, SL = LO, sense LO

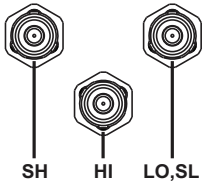

The Model 2600A#2 connectors provide sense HI, HI, LO, and sense LO input connections for Model 2600A instruments.

Connections are as follows:

- SH = Sense HI
- HI = HI
- LO, SL = LO, sense LO

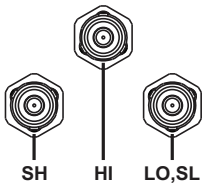

The Model 2600A#1 connectors provide sense HI, HI, LO, and sense LO input connections for Model 2600A instruments.

Connections are as follows:

- SH = Sense HI
- HI = HI
- LO, SL = LO, sense LO

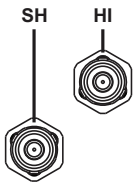

The 4200-SMU connectors provide sense HI and HI input connections for Model 4200-SMU instruments.

Connections are as follows:

- SH = Sense HI
- HI = HI

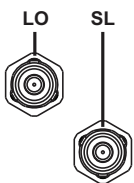

The 4200 GND UNIT connectors provide LO and sense LO input connections for Model 4200-SMU instruments.

Connections are as follows:

- LO = LO
- SL = Sense LO

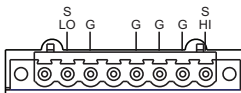

The 2651A #2 SENSE/GUARD connector provides Model 2651A input connections for sense HI, sense LO, and guard. Connections are as follows:

- S LO = Sense LO
- G = Guard
- S HI = Sense HI

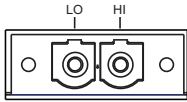

The 2651A#2 INPUT connector provides Model 2651A input connections for LO and HI.

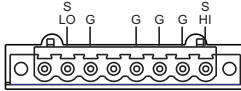

The 2651A #1 SENSE/GUARD connector provides Model 2651A input connections for sense HI, sense LO, and guard. Connections are as follows:

- S LO = Sense LO
- G = Guard
- S HI = Sense HI



The 2651A#1 INPUT connector provides Model 2651A input connections for LO and HI.



Ground screws for connections to protective earth (safety ground).



The 4200 Interlock provides an interlock connection for the Model 4200-SMU and 4210-SMU instruments.

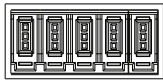

The Model 26XXA Interlock provides interlock connections for the Model 2611A, 2612A, 2635A, 2636A, 2651A, and 2657A instruments. You can have multiple interlocks connected. You can use any one of the interlock connectors.

Installing the test boards

The Model 8010 is shipped with two 8010-DTB Device Test Boards installed. The boards include connections for TO-247 and axial-lead devices.

The Model 8010 is also shipped with an 8010-CTB Customizable Test Board, which allows you to add your own connections.

In addition, you can purchase the 8010-DTB-220 Device Test Board for use with three-terminal TO-220 or TO-247 devices. This board is limited to 1000 V.

You can also purchase replacement 8010-DTB boards and 8010-CTB boards.

The following instructions explain how to replace a pre-installed test board with another test board.

! WARNING

Before installing or replacing test boards, make sure you remove all electrical connections to the test fixture. Failure to disconnect power may result in personal injury or death due to electric shock.

Tool required

- Medium Phillips head screwdriver

Assembly instructions**NOTE**

If you are customizing the 8010-CTB Customizable Test Board, make customizations before installing it in the Model 8010.

1. Remove any external power that is connected to the test fixture through connected devices or devices under test (DUTs).
2. In the test fixture, remove the four Phillips flat-head screws that secure the board you want to replace.
3. Set the replacement board in the test fixture with the yellow connectors (connectors 3 and 6) oriented toward the rear of the fixture. Line up the pre-drilled screw holes in the board with the screw holes in the fixture.
4. Thread four of the Phillips flat-head screws through the replacement board.
5. Tighten the screws.

Figure 2: Model 8010 device test board installation

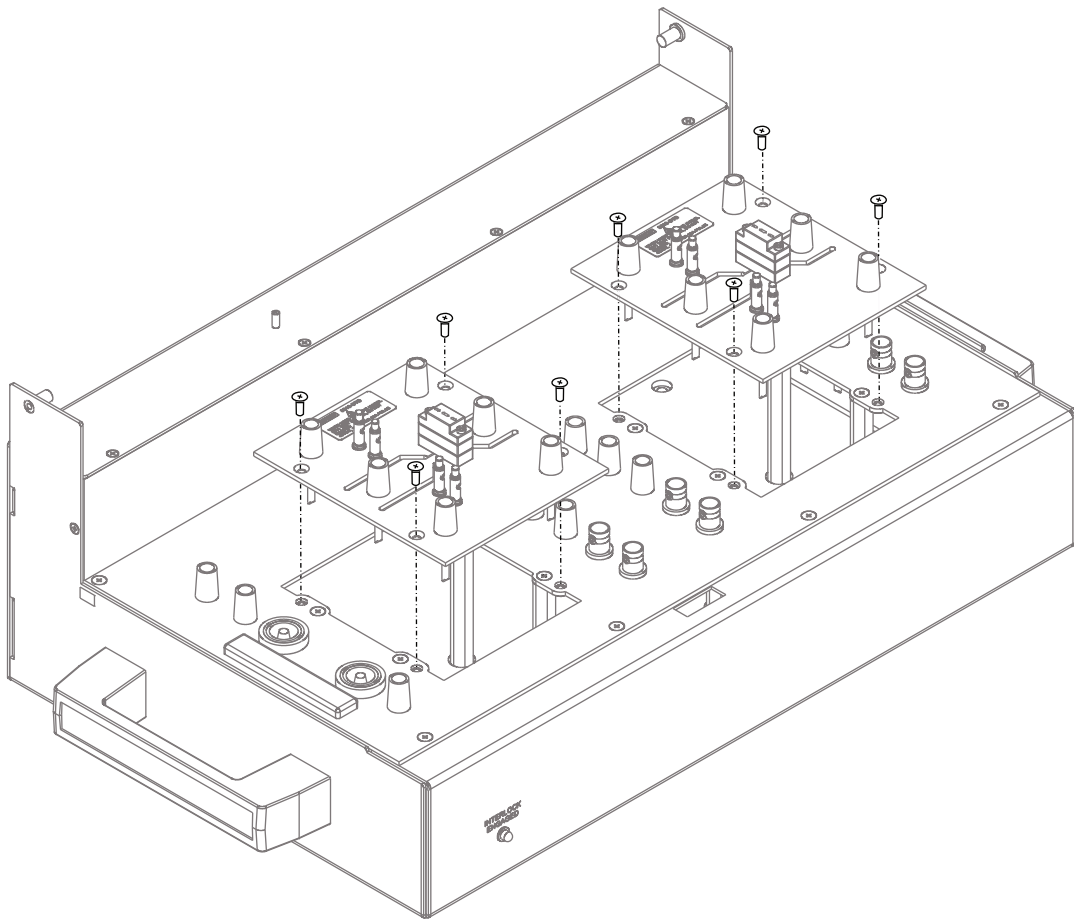

Using the interlock

The Model 8010 can be connected to instruments that can output hazardous live voltages. To ensure operator safety, the Model 8010 provides a built-in interlock switch. The interlock switch is engaged when the Model 8010 lid is closed and latched. When the interlock switch is engaged, the light on the lower left of the Model 8010 enclosure is illuminated. You can turn on a SMU output only when the interlock switch is engaged.

If the lid is open, the interlock switch will not engage and any SMUs with outputs that are configured for high voltage will not turn on.

If the lid of the Model 8010 test fixture opens:

- The interlock switch opens and the interlock is disengaged.
- The interlock pin is pulled low.
- The output of the SMU turns off.

If the interlock switch is disengaged, the outputs of any instruments with interlock connections to the test fixture are turned off. The outputs cannot be turned back on until the interlock switch is engaged. The output is not automatically turned on when the interlock switch is engaged.

For detailed information on the interlock requirements for a specific SMU, see the reference manual for that SMU.

Connections to the rear panel

This section describes the connections you can make to the rear panel of the Model 8010.

WARNING

The ground wires must be attached to a known protective earth (safety ground) before powering on instruments. Failure to attach the ground wires to a known protective earth may result in electric shock.

The input/output terminals of the Model 8010 High Power Device Test Fixture are rated for connection to circuits rated Installation Category I only, with transients rated less than 1500 V peak above the rated input. Do not connect the Model 8010 terminals to CAT II, CAT III, or CAT IV circuits. Connection of the Model 8010 terminals to circuits higher than CAT I can cause damage to the equipment or expose the operator to hazardous voltage.

Model 2611A and Model 2612A connections

The Model 8010 includes internal protection circuitry for the Model 2611A and 2612A SMUs. If there is a device under test (DUT) failure, this circuitry protects the SMUs from high voltage from the Model 2657A.

NOTE

The LO terminal is connected to chassis ground if you connect the Model 2611A or 2612A to the Model 8010 through the Model 2600-TRIAX.

CAUTION

Do not convert triaxial cables to BNC cables. Using BNC cables will remove protection from SourceMeter Instrument voltages and may result in instrument damage. You must use triaxial cables.

Figure 3: Model 8010 to Model 2611A or 2612A rear panel connections

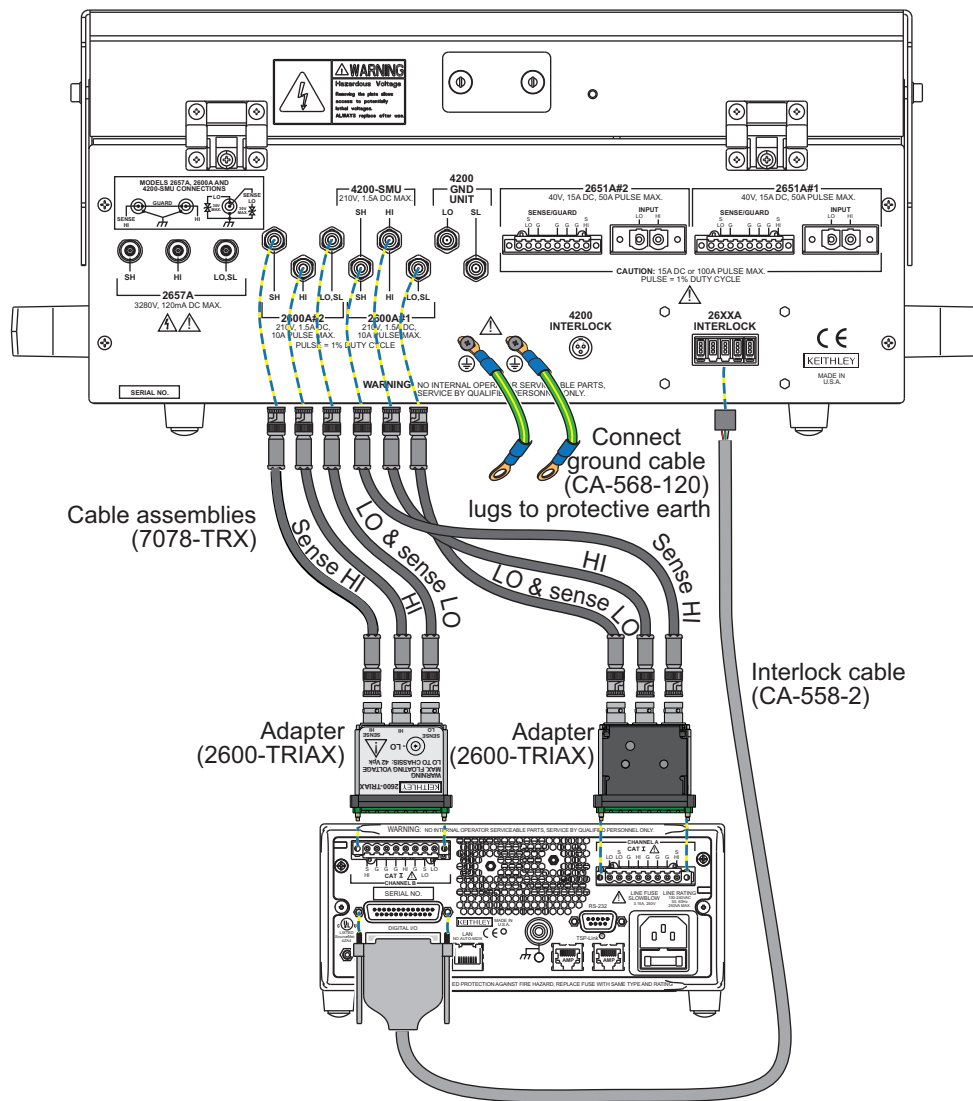

Model 2635A and Model 2636A connections

The Model 8010 includes internal protection circuitry for the Model 2635A and 2636A SMUs. In the case of a device under test (DUT) failure, this circuitry protects the SMUs from high voltage from the Model 2657A.

⚠ CAUTION

Do not convert triaxial cables to BNC cables. Using BNC cables will remove protection from SourceMeter Instrument voltages and may result in instrument damage. You must use triaxial cables.

Figure 4: Model 8010 to Model 2635A and Model 2636A rear panel connections

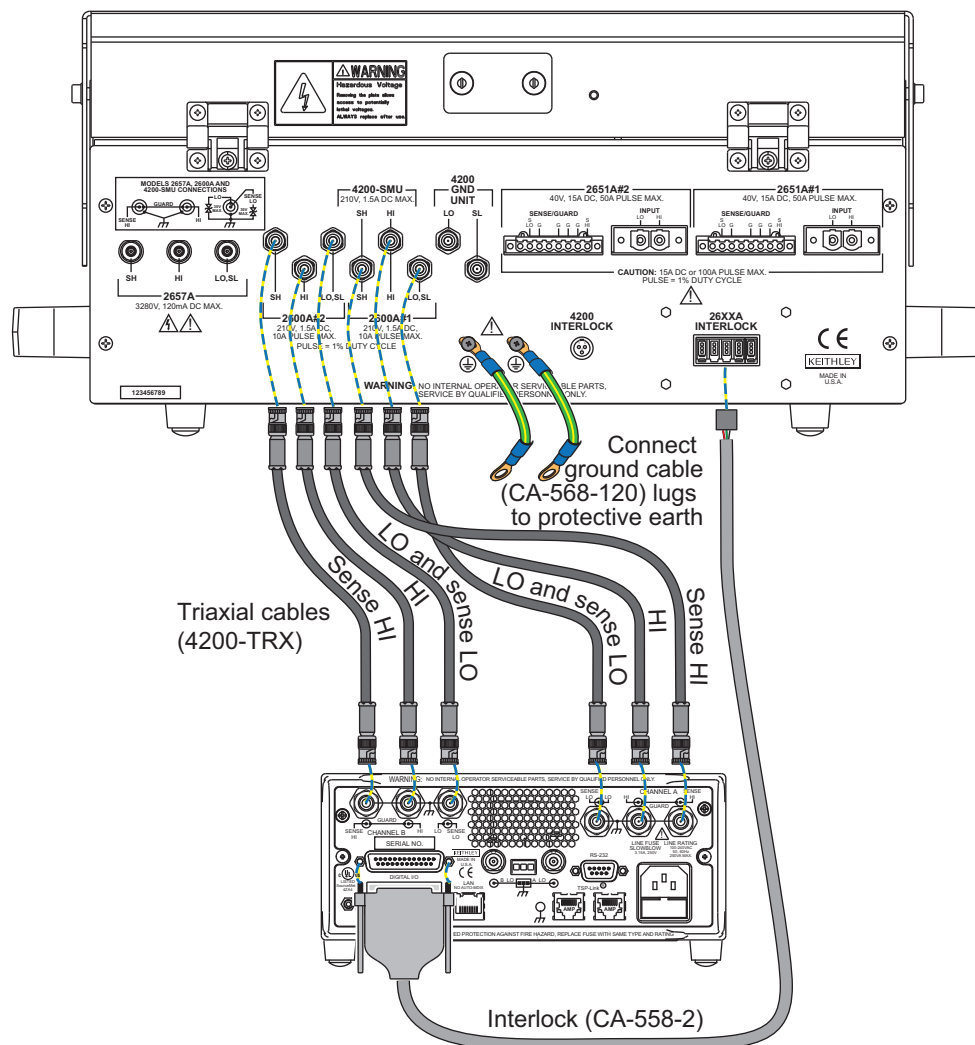

Model 2651A connections

NOTE

There is no safety interlock on the Model 2651A — the safety interlock is not necessary because output voltage of the Model 2651A is below hazardous levels. The CA-558-2 cable is shown here in case you want to use Output Enable to shut off the output when the Model 8010 lid is opened. To activate Output Enable, refer to the Model 2651A Reference Manual. Output Enable can be activated using the front panel or by remote control.

Figure 5: Model 8010 to Model 2651A wiring diagram

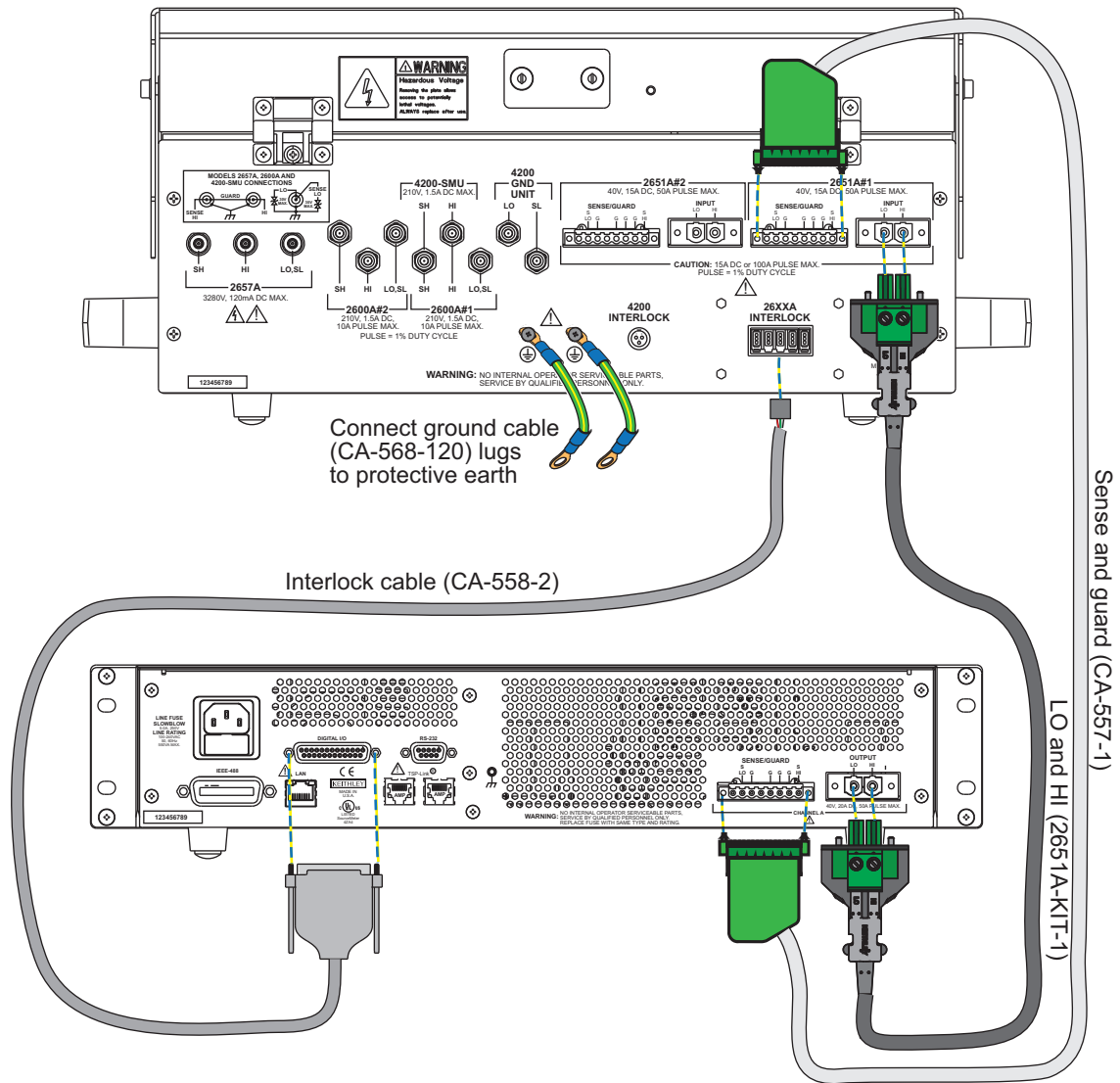

Model 2657A connections

Figure 6: Model 8010 to Model 2657A rear panel connections

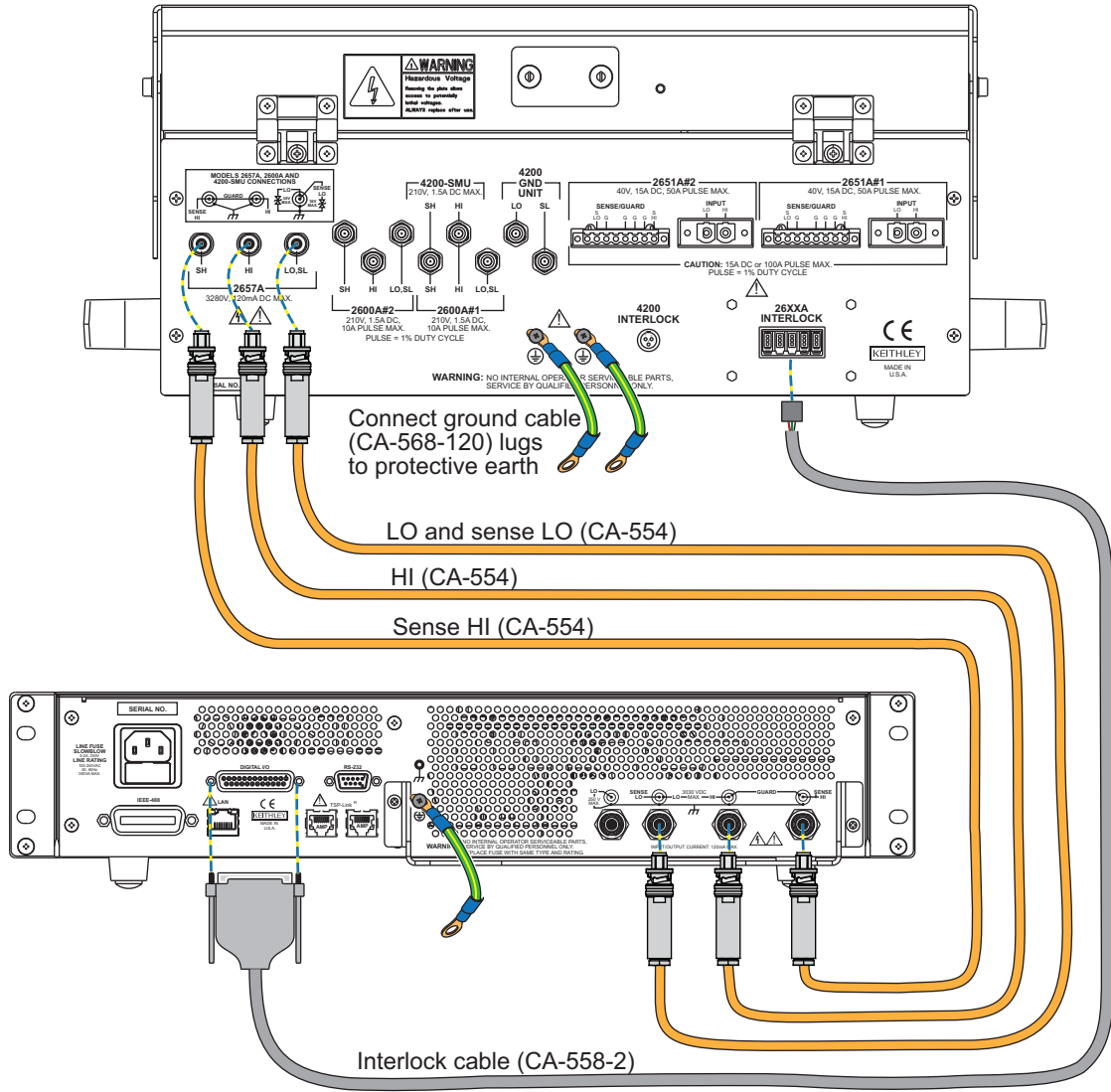

Model 4200 and Model 4210-SMU connections

The Model 8010 includes internal protection circuitry for the Models 4200 and 4210-SMU. In the case of a device under test (DUT) failure, this circuitry protects the SMUs from high voltage from the Model 2657A.

NOTE

The LO terminal is connected to chassis ground once you connect the Model 4200 or 4210-SMU to the Model 8010.

CAUTION

Do not convert triaxial cables to BNC cables. Using BNC cables will remove protection from SourceMeter Instrument voltages and may result in instrument damage. You must use triaxial cables.

Figure 7: Model 8010 to Model 4200 and Model 4210-SMU wiring diagram

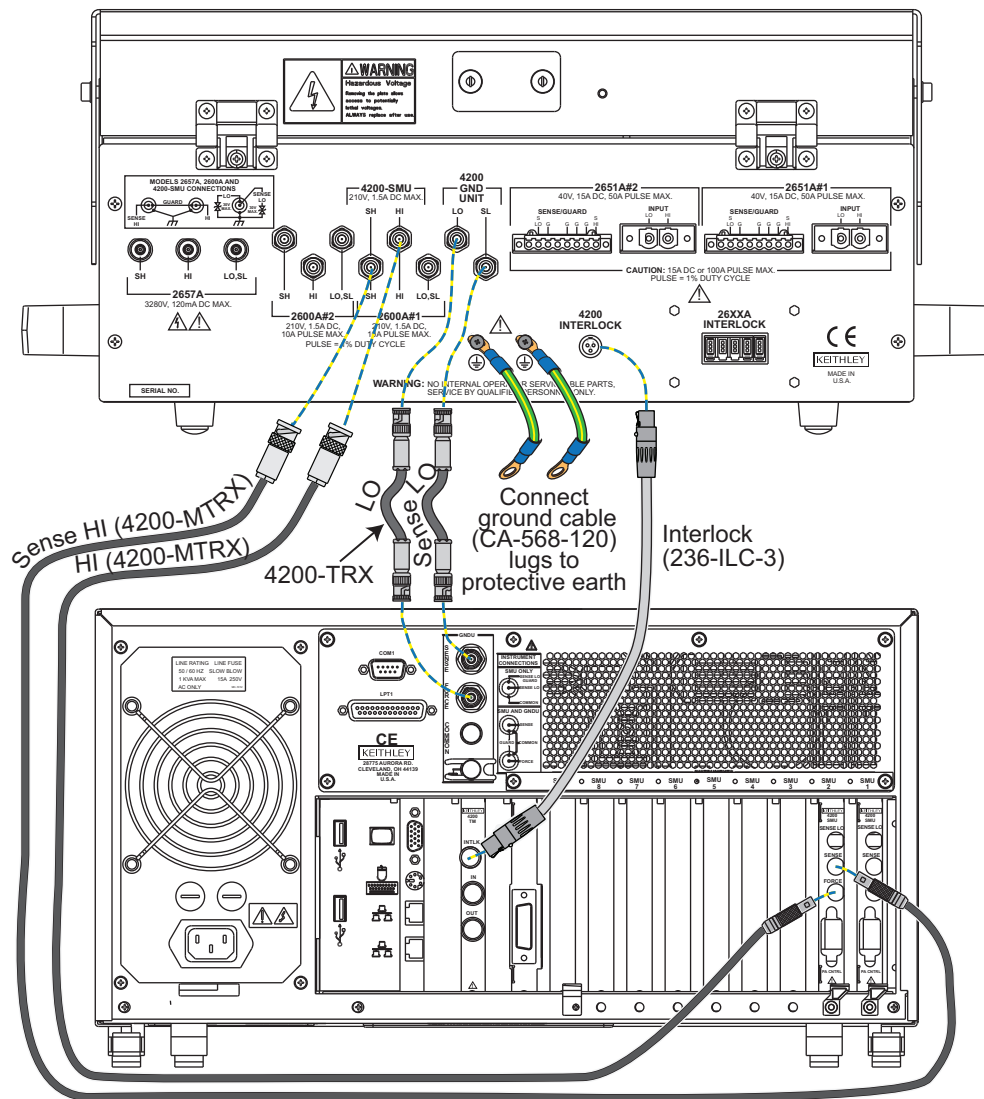

Model 4200 and Model 4210-SMU with preamplifier connections

The Model 8010 includes internal protection circuitry for the Models 4200 and 4210-SMU. In the case of a device under test (DUT) failure, this circuitry protects the SMUs from high voltage from the Model 2657A.

NOTE

The LO terminal is connected to chassis ground once you connect the Model 4200 or 4210-SMU to the Model 8010.

CAUTION

Do not convert triaxial cables to BNC cables. Using BNC cables will remove protection from SourceMeter Instrument voltages and may result in instrument damage. You must use triaxial cables.

Figure 8: Model 8010 to Model 4200 or Model 4210-SMU with preamplifier rear panel connections

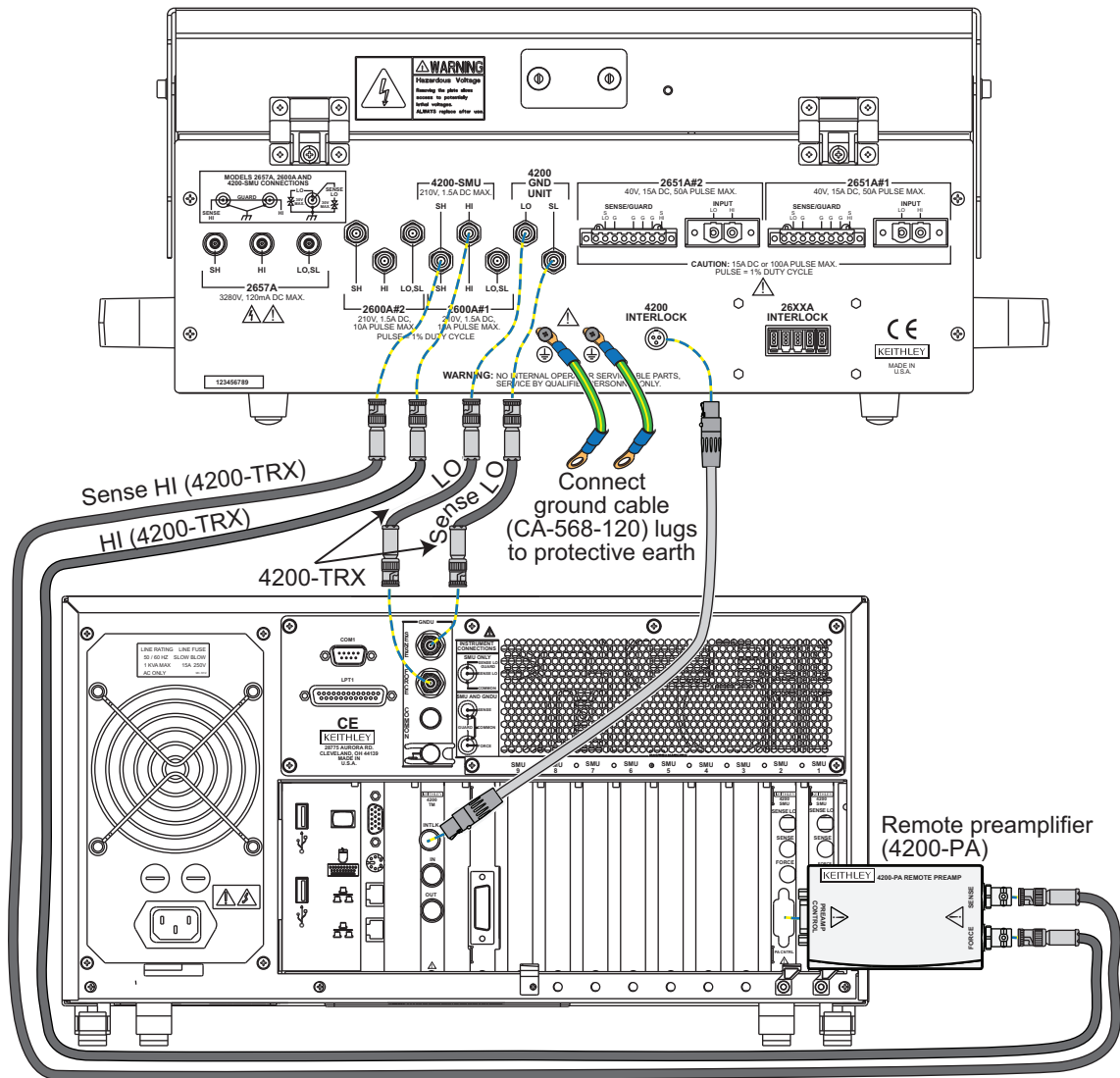

Internal protection circuitry

The Model 8010 includes internal protection circuitry that protects instruments in applications where a device breakdown or other potential failure could connect the high-voltage output of a Model 2657A high-voltage SMU to a lower voltage SMU.

The Model 8010 includes internal protection circuitry for the Models 2611A, 2612A, 2635A, 2636A, 4200, and 4210 SMUs. The protection circuitry is automatically connected whenever you make connections between the Model 8010 and these SMUs.



CAUTION

Do not convert triaxial cables to BNC cables. Using BNC cables will remove protection from SourceMeter Instrument voltages and may result in instrument damage. You must use triaxial cables.

Using the access port on the Model 8010

The rear panel of the lid of the Model 8010 contains an access port. This port can be used to bring in connections for external instrumentation. For example, you could route oscilloscope probes through the access port to the device under test or to the guard terminal of the instruments connected to the Model 8010.



WARNING

Before removing the access port cover plate, make sure you remove all power sources to the test fixture. Failure to disconnect power may result in personal injury or death due to electric shock.



WARNING

Removal of the access port cover plate may expose the user to hazardous live voltages. Always replace the access port cover plate after use. Failure to do so could expose the user to hazardous voltages that could result in personal injury or death.

To use the access port:

1. Remove the access port cover plate.
2. Route external connections through the access port.
3. After testing is complete, replace the access port cover plate.



CAUTION

If you use the access port to route an oscilloscope probe, be sure to use a probe that is rated for the maximum current or voltage expected in your test setup. Failure to do so can result in equipment damage.



Quick Tip

If you wish to use the oscilloscope voltage probe to monitor the instrument output, connect the probe to the Guard terminal to avoid loading the device under test.

Working with devices and instruments

In this section:

Safety information	3-1
About the device test boards	3-1
Installing a device in the axial posts	3-2
Installing a device in the TO socket	3-3
Using the insulating plug	3-3
Measurement considerations	3-4
Using the guard terminal	3-8

Safety information

WARNING

Verify that all wiring is to the inside of the cross-hatched area of the test fixture. Ensure that wires do not protrude beyond the fixture lid and that the lid will close securely. Exposed wire may result in electric shock, causing death or serious injury.

Hazardous voltages may be present on the output and guard terminals. To prevent electrical shock that could cause injury or death, never make or break connections to the Model 8010 while the output from the SourceMeter Instrument (SMU) is on. Power off the instrument from the front panel or disconnect the main power cord from the rear of the instrument before handling cables connected to the outputs. Putting the instrument into standby does not guarantee that the outputs are powered off if a hardware or software fault occurs.

Remove power from any connected SourceMeter Instruments before making connections.

Make connections to the SourceMeter Instruments before making connections to the Model 8010.

About the device test boards

The 8010-DTB and 8010-DTB-220 Device Test Boards include sockets for three-terminal and axial-lead devices. The connections available on the boards allow you to make 2-wire (local) or 4-wire (remote) test connections.

The socket has true remote sense connections to each pin, with two binding posts connected to each terminal of the device. One set of binding posts is intended for force connections and the other for sense connections.

When making connections:

- Connect force leads to binding posts 4, 5, and 6
- Connect sense leads to binding posts 1, 2, and 3

These pins are connected internally to each other (binding post 1 to post 4, 2 to 5, and 3 to 6). However, posts 4, 5, and 6 have a shorter path to the socket than posts 1, 2, and 3, which results in a lower resistance path. This is particularly important for high-current applications.

When testing axial-lead devices, note that posts 1 and 3 put the sense leads closer to the device under test. This reduces measurement error due to lead resistance.

Figure 9: Force and sense binding posts

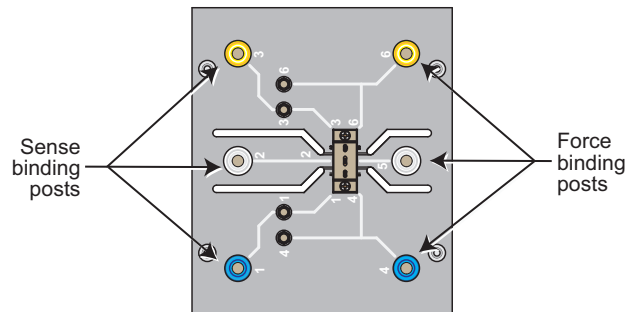

Two 8010-DTB high power socket module test boards are installed in the Model 8010. The Model 8010 is also shipped with an 8010-CTB Customizable Test Board, which allows you to add your own connections.

In addition, you can purchase the 8010-DTB-220 Device Test Board for use with three-terminal TO-220 or TO-247 devices. You can also purchase replacement 8010-DTB and 8010-CTB boards.

Installing a device in the axial posts

This section discusses how to install devices in the axial terminal posts on the 8010-DTB or 8010-DTB-220 Device Test Board.

To install a device in the axial posts:

1. Insert the device in the axial posts.
2. Insert the insulating plug in the TO socket terminals if needed. See [Using the insulating plug](#) (on page 3-3) for detail.

See [Axial-lead device high current test](#) (on page 5-1) for an example.

Figure 10: Model 8010-DTB and DTB-220 axial leads and TO socket

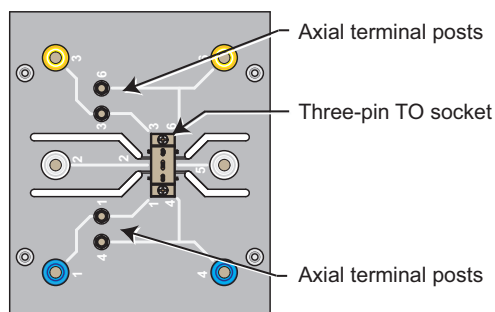

Installing a device in the TO socket

This section explains how to install a device in the TO socket of the 8010-DTB or 8010-DTB-220 board.

To install a device in the TO socket:

1. Remove the insulating plug (if used) from the three-pin socket.
2. Verify that the four axial terminal posts are not connected to anything.
3. Place the TO-220 or TO-247 device into the pins of the three-pin socket. If you are installing a two-terminal device, place the device into the outer pins.

See [Off-state characterization of a power MOSFET](#) (on page 4-1) and [On-state characterization of a power MOSFET](#) (on page 6-1) for examples.

NOTE

The two-terminal interconnection diagrams that are shown in the "Model 8010 Interconnection Reference Guide" are intended for axial-lead devices. However, you can adapt the setups so that you can test two-terminal TO-220 and TO-247 devices.

Using the insulating plug

The Model 8010 comes with insulating plugs. These plugs can be installed in the TO sockets of the 8010-DTB and 8010-DTB-220 boards when you are testing two-terminal devices that are installed in the axial-lead terminal posts. In general:

- You will use the insulating plug when measuring lower resistance devices.
- Do not use the insulating plug when measuring devices with resistances greater than 1 M Ω .

The three-pin socket on the device test boards inherently shorts the force and sense pins together. When you are using the axial terminal posts in 4-wire mode, this can cause measurement errors. You should insert the insulating plug into the three-pin socket when testing devices with axial leads in 4-wire sense mode where a short between force and sense will cause measurement errors.

Do not use the insulating plug when testing devices with higher resistance (greater than 1 M Ω). Using the plug for these tests may cause leakage measurement errors.

Measurement considerations

The following topics describe some considerations you should be aware of when taking measurements.

With the Model 8010, you can make measurements using either 2-wire (local) or 4-wire (remote) sensing. Examples of each are shown in the "Model 8010 Interconnection Reference Guide."

The 2-wire sensing method requires only two test leads. However, as shown in the following figure, test lead resistance can seriously affect the accuracy of 2-wire resistance measurements, particularly when measuring lower resistance values.

Figure 11: 2-wire resistance sensing

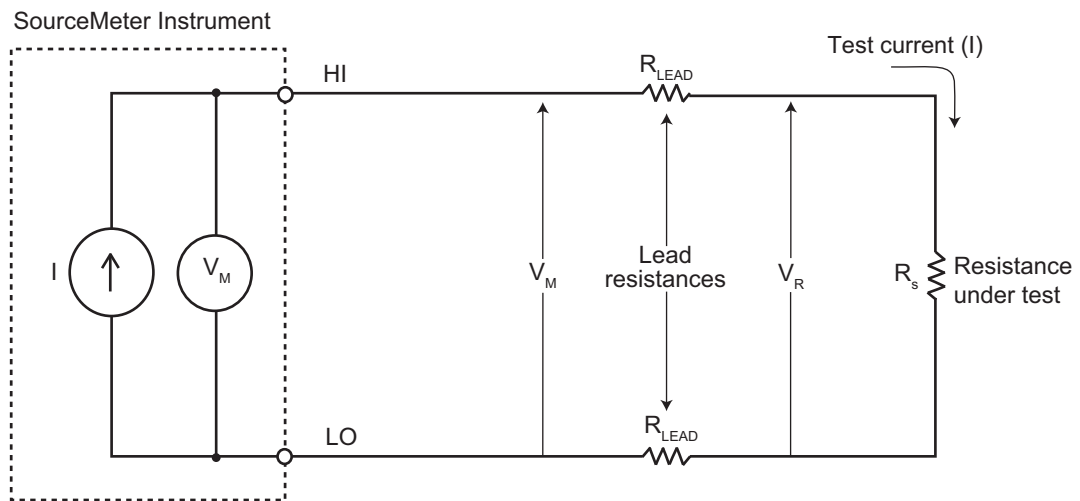

- I = Current sourced
- V_M = Voltage measured
- V_R = Voltage across resistor

$$\text{Measured resistance} = \frac{V_M}{I} = R_s + (2 \times R_{LEAD})$$

$$\text{Actual resistance} = \frac{V_R}{I} = R_s$$

The 4-wire sensing method, as shown in the following figure, minimizes or eliminates the effects of lead resistance by measuring the voltage across the resistor under test with a second set of test leads. Because of the high input impedance of the voltmeter, the current through the sense leads is negligible, and the measured voltage is essentially the same as the voltage across the resistor under test.

Figure 12: 4-wire resistance sensing

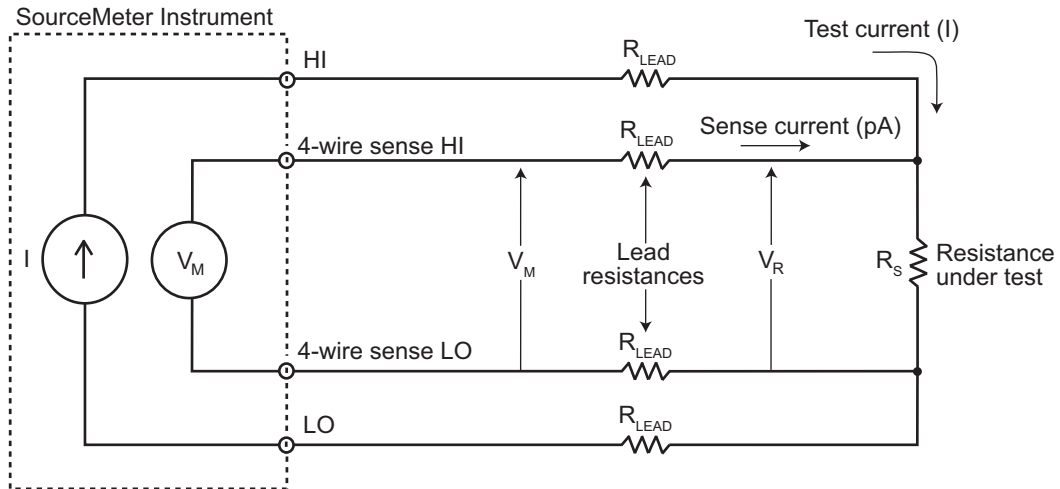

I = Current sourced by SourceMeter
 V_M = Voltage measured by SourceMeter
 V_R = Voltage across resistor
 Because sense current is negligible, $V_M = V_R$
 and measured resistance = $\frac{V_M}{I} = \frac{V_R}{I} = R_s$

NOTE

Four-wire remote sense is recommended when device resistances are low enough (less than 1kΩ) that resistance in the test leads will cause significant error in the measurement. For more information, in the Series 2600A or Model 2651A Reference Manual, see "DUT test connections" for information on two-wire and four-wire sensing.

If you are using remote sense connections in the Model 8010, you must enable remote sense on the instrument.

Suppressing device oscillations

During on-state characterization of MOSFET and IGBT devices, high-current pulses that travel through the channel of the device may cause the gate of the device to oscillate. The instability of the gate voltage will result in unstable measurements through the device channel.

To dampen these oscillations and stabilize the gate, you can insert a resistor between the gate of the device and the SourceMeter Instrument (SMU) connected to the gate. See [How to insert a resistor on a device terminal](#) (on page 3-6) for detail.

The appropriate gate resistor value is device-dependent. However, typical gate resistor values range from tens to hundreds of ohms.

If the gate remains unstable after inserting a dampening resistor, enable the high-capacitance mode (if available) on the SMU connected to the gate.

How to insert a resistor on a device terminal

The Model 8010 is equipped to connect a standard resistor with axial leads to any device terminal.

To connect a resistor to the Model 8010:

1. Loosen the screw-down clamp of the terminal post you wish to connect to.
2. Insert one lead of the resistor into the hole below the screw-down clamp.
3. Tighten the screw-down clamp until the resistor is held firmly to the terminal post.
4. Connect an alligator clip (customer-supplied) to the banana plug of the jumper wire coming from the force lead of the SMU to be connected.
5. Clip the alligator clip to the other end of the resistor.

Figure 13: Model 8010 two-wire test with a gate resistor installed

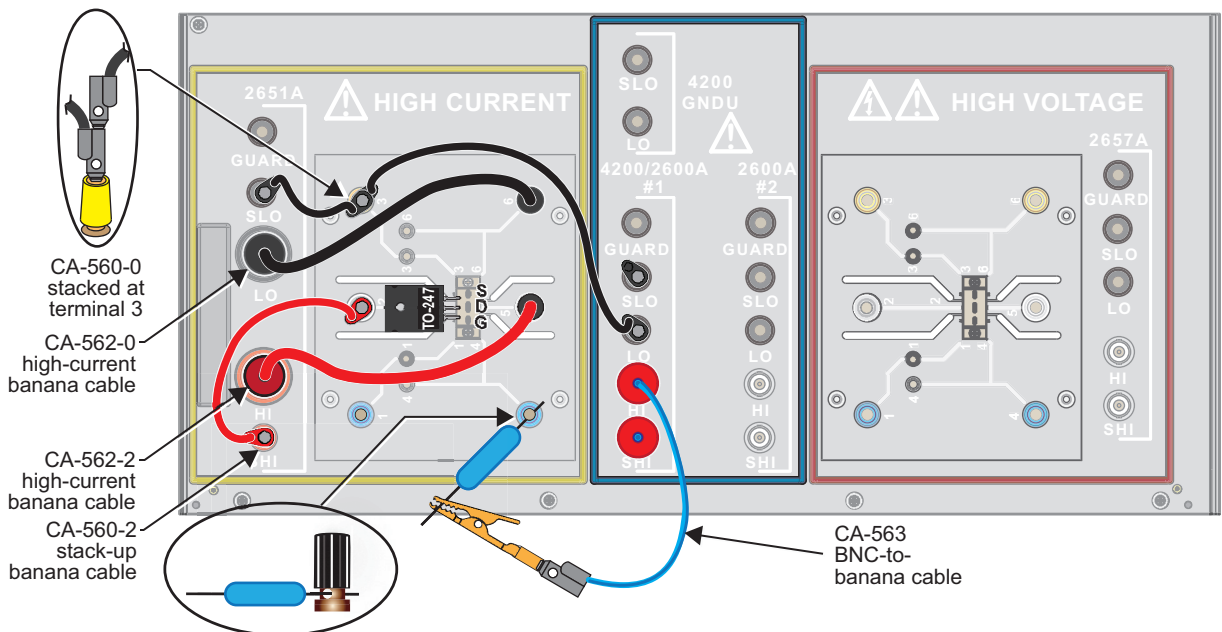

If you are using a four-wire configuration, the sense lead of the SMU will need to be connected to the same side of the resistor as the source lead. To connect both the sense and source leads to the same side of the resistor, stack the ends of the force and sense lead jumpers together, then connect them to the customer-supplied alligator clip.

Figure 14: Four-wire remote sense with gate resistor

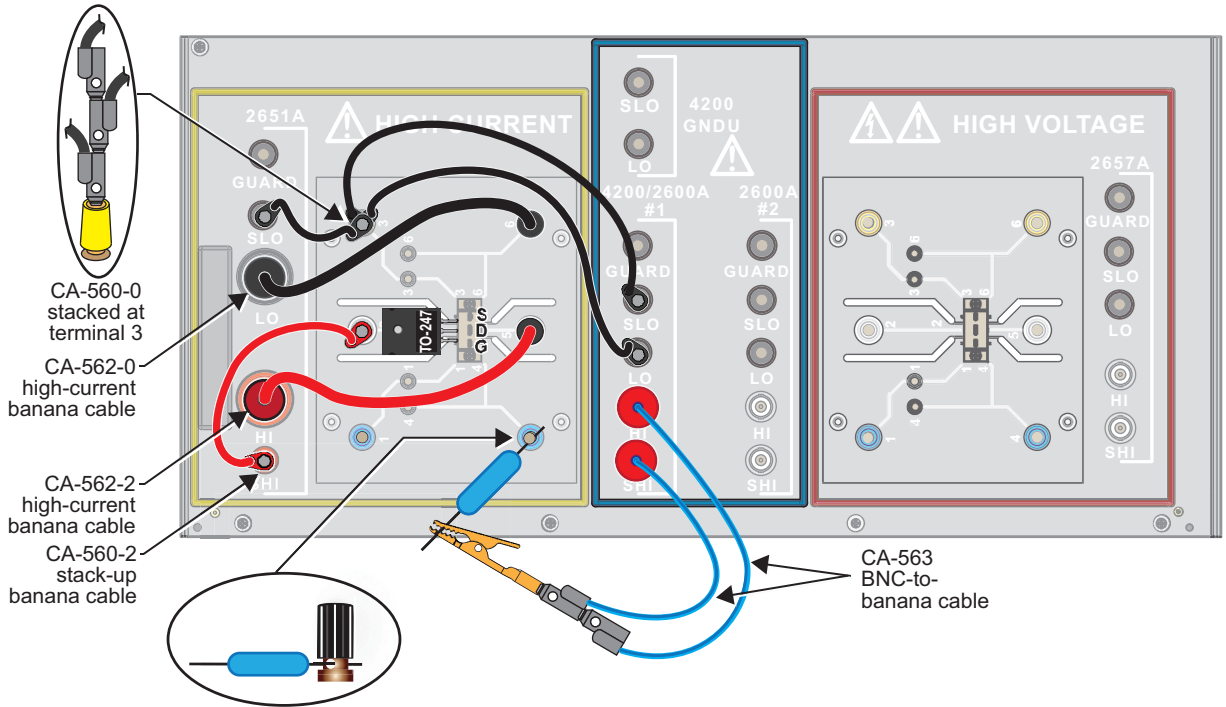

Using the guard terminal

WARNING

Never connect the guard terminal from any instrument to the LO terminal of any instrument in the Model 8010 or to the chassis. Connecting guard to LO can disable the high voltage protection that is installed across the Model 4200 or Model 2600A SourceMeter Instrument connections. This may result in hazardous live voltages being present at the HI, SHI, SLO, or LO terminals.

The guard terminal is useful for maintaining low-leakage measurements if you are using the customized test board or if you are monitoring the test through the access port on the rear of the lid.

The driven guard is always enabled and provides a buffered voltage that is at the same level as the HI (or sense HI for remote sense) voltage. This allows you to monitor the output of the SourceMeter instrument (SMU) without disturbing the device under test. For example, you can monitor the SMU with an oscilloscope probe routed through the access port of the Model 8010.

The purpose of guarding is to eliminate the effects of leakage current (and capacitance) that can exist between high and low. In the absence of a driven guard, leakage in the external test circuit could be high enough to adversely affect the performance of the SourceMeter Instrument.

Leakage current can occur through parasitic or nonparasitic leakage paths. An example of parasitic resistance is the leakage path across the insulator in a coaxial or triaxial cable. An example of nonparasitic resistance is the leakage path through a resistor that is connected in parallel to the device under test (DUT).

Guard is typically used to drive the guard shields of cables and test fixtures. Guard is extended to a test fixture from the cable guard shield. Inside the test fixture, the guard can be connected to a guard plate or shield that surrounds the device under test (DUT). Note that the 8010-DTB and 8010-DTB-220 device test boards do not have guard plates or shields. However, you can use the 8010-CTB customizable test board to build custom connections that completely guard the connections all the way to the device terminals.

WARNING

To prevent injury or death, a safety shield must be used to prevent physical contact with a guard plate or guard shield that is at a hazardous potential (>30 V RMS or 42.4 V peak). This safety shield must completely enclose the guard plate or shield and must be connected to safety earth ground. The graphic below shows the metal case of a test fixture being used as a safety shield. The lid of the Model 8010 serves as the safety shield.

The figures below show how a cable guard can eliminate leakage current through the insulators in a test fixture. In these figures, leakage current (I_L) flows through the insulators (R_{L1} and R_{L2}) to LO, adversely affecting the low-current (or high-resistance) measurement of the DUT.

Also in the figures below, the driven guard is connected to the cable shield and extended to the metal guard plate for the insulators. Since the voltage on either end of R_{L1} is the same ($0 V_{drop}$), no current will flow through the leakage resistance path. Thus, the SourceMeter instrument only measures the current through the DUT.

Note that the Model 8010 is a safety shield.

Figure 15: Unguarded measurements

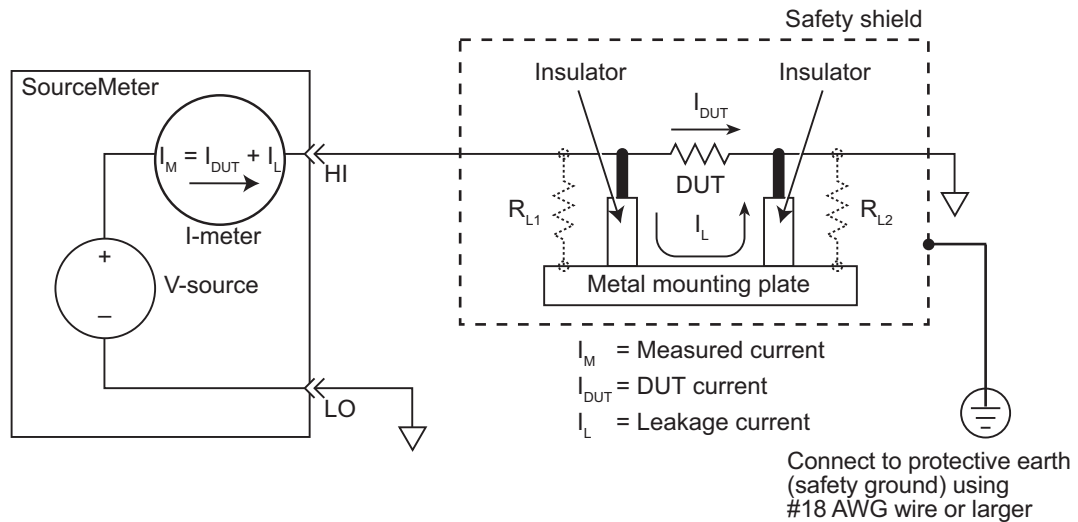
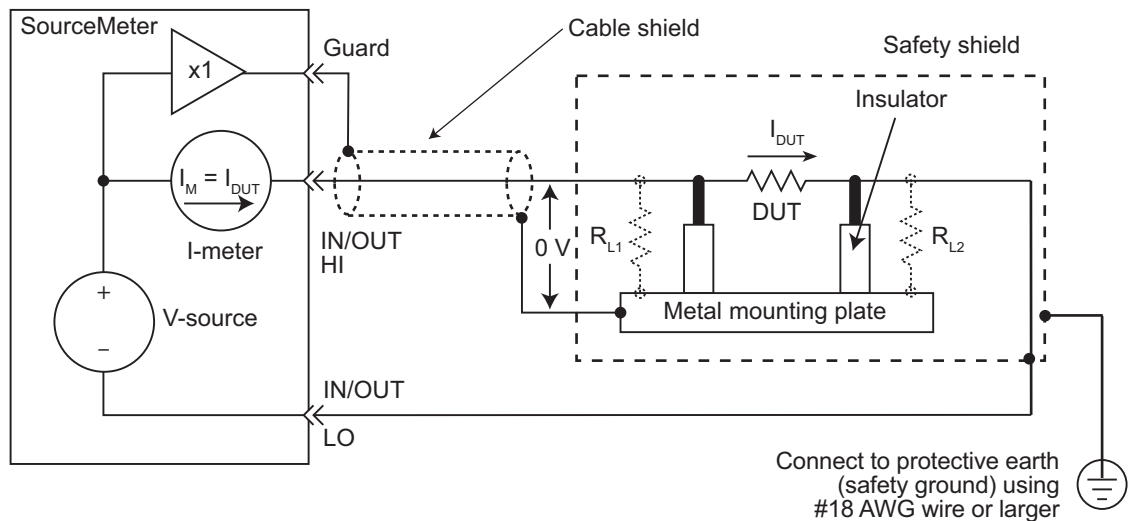

Figure 16: Guarded measurements



Off-state characterization of a power MOSFET

In this section:

Introduction	4-1
Equipment needed	4-2
Set up communication.....	4-2
Device connections	4-3
Install the device and make connections.....	4-6
BV _{dss} measurement.....	4-6
I _{dss} measurement.....	4-9

Introduction

This example characterizes the drain-to-source off-state performance of a power MOSFET in a TO-247 package in the high-voltage side of the Model 8010.

It demonstrates how to program the Models 2657A and Series 2600A to perform BV_{dss} and I_{dss} measurements. For a BV_{dss} measurement, a test current is applied to the drain of the device while it is in the off state and a voltage is measured that corresponds to the drain-to-source breakdown voltage. For I_{dss} measurements, a drain voltage (V_{ds}) versus drain current (I_d) curve is generated while applying a gate voltage (V_{gs}) that ensures that the device is in the off state. The Model 2657A is used to supply the drain voltage and make measurements of drain voltage and drain current. The Series 2600A is used to provide the gate voltage.

NOTE

You can also use this example to test an IGBT in a TO-247 package. You will need to make two substitutions:

Substitute the collector terminal of the IGBT for the drain terminal of the FET

Substitute the emitter terminal of the IGBT for the source terminal of the FET

Equipment needed

Equipment required:

- One Model 8010 High Power Test Fixture with the Model 8010-DTB board installed on the high voltage side of the test fixture (see [Installing the test boards](#) (on page 2-3) for more information)
- One Model 2657A High Power System SourceMeter instrument
- One Series 2600A System SourceMeter instrument
- One power MOSFET in a TO-247 package
- Cables to connect the Model 2657A to the Model 8010: Three Model CA-554 cable assemblies
- Cables to connect the Series 2600A to the Model 8010: Three Model 7078-TRX cable assemblies
- One CA-558-2 interlock cable
- Model 2611A or 2612A only: Adapter to connect the SMU to the Model 8010: One Model 2600-TRIAx triaxial adapter
- Cables to connect instruments to the device in the Model 8010: Two Model CA-563 and two Model CA-560-0 cables
- One GPIB cable or Ethernet cable
- One TSP-Link cable

Set up communication

The communication setup is illustrated in the following diagram. GPIB is used as an example, but this application can be run using any of the supported communication interfaces for the instruments.

Figure 17: GPIB and TSP-Link communications setup

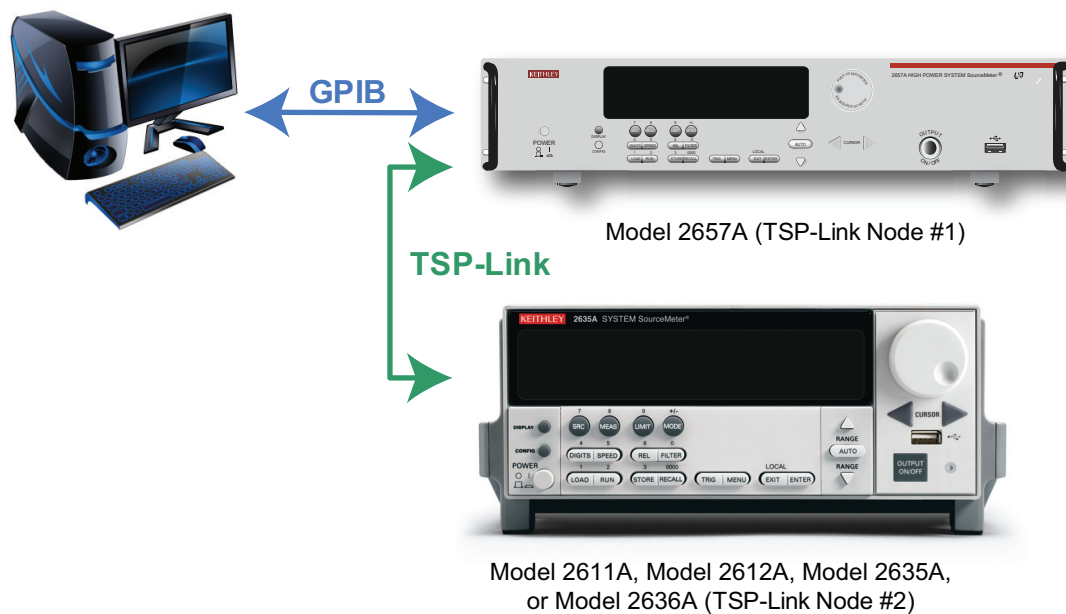

Device connections

Connect instruments to the Model 8010

Refer to the appropriate figures below to connect your SourceMeter instrument to the Model 8010.

⚠ WARNING

The ground wires must be attached to a known protective earth (safety ground) before powering on instruments. Failure to attach the ground wires to a known protective earth (safety ground) may result in electric shock.

Figure 18: Model 8010 to Model 2611A or 2612A rear panel connections for MOSFET application example

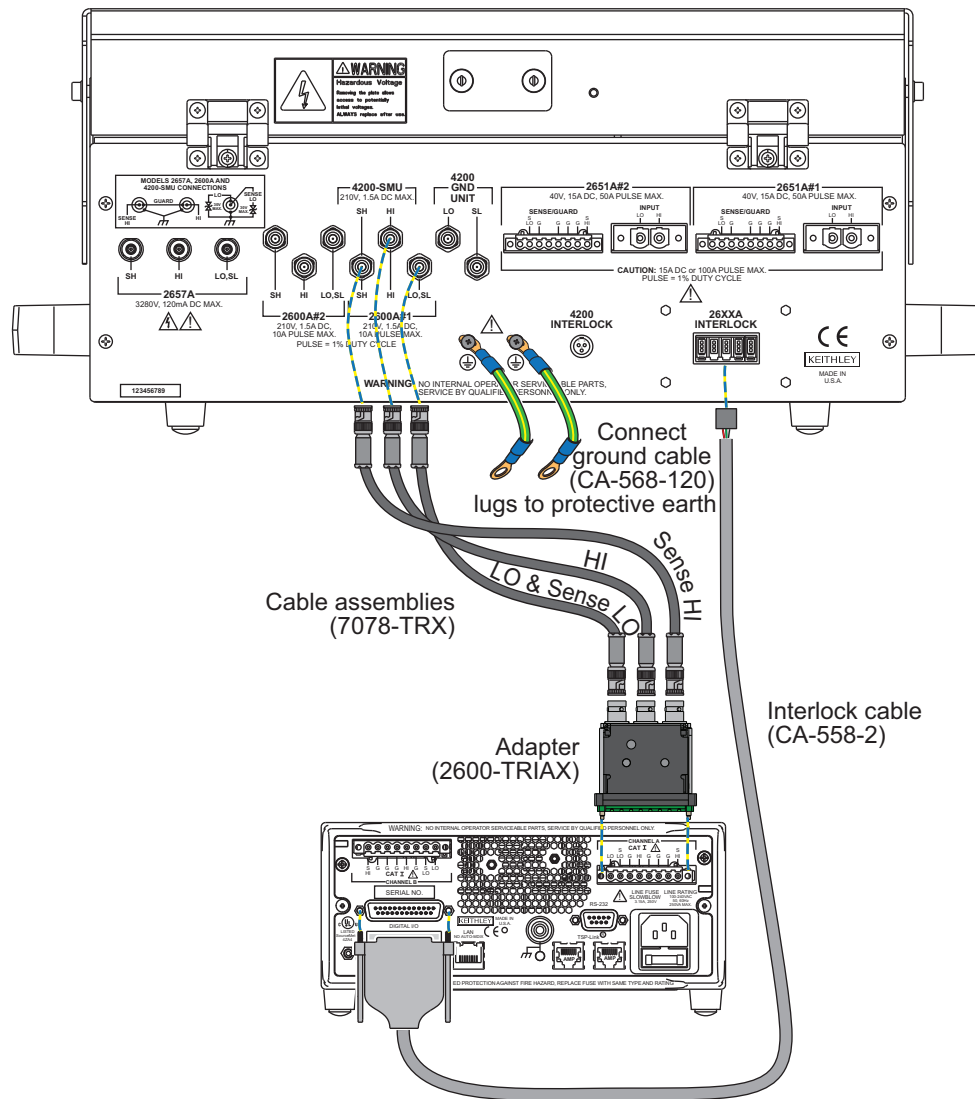

Figure 19: Model 8010 to Model 2635A or 2636A rear panel connections for MOSFET application example

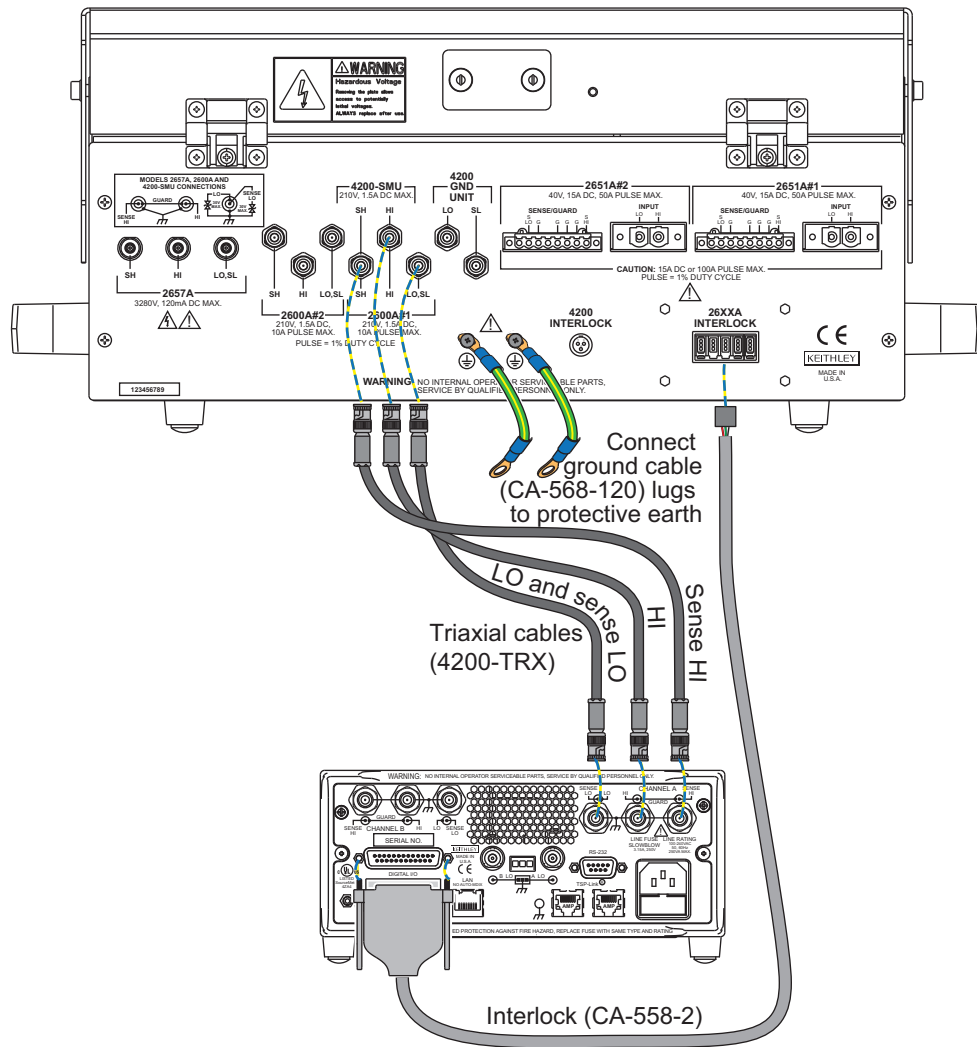
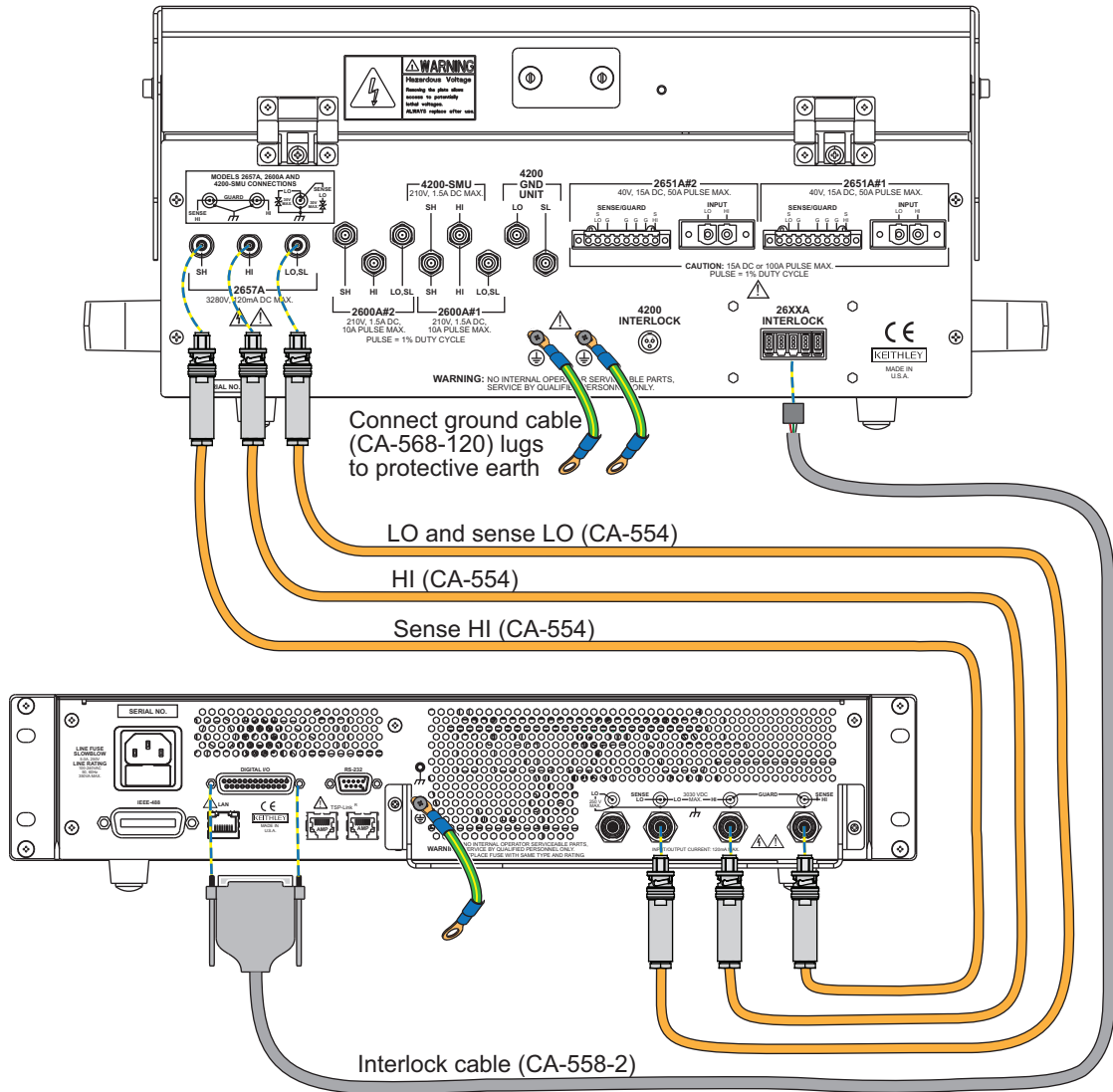

Figure 20: Model 8010 to Model 2657A rear panel connections



Install the device and make connections

To install a device in the Model 8010 and connect instruments to the device:

1. Ensure that the Model 8010-DTB test board is installed. Refer to [Installing the test boards](#) (on page 2-3).
2. Remove the insulating plug if installed.
3. Install the device in the socket so that the gate terminal is connected to pins 1 and 4 of the device test board.
4. Make the connections as shown in the graphic below.

Figure 21: Three-terminal DUT with a Model 2657A and a Series 2600A connected (local sense)

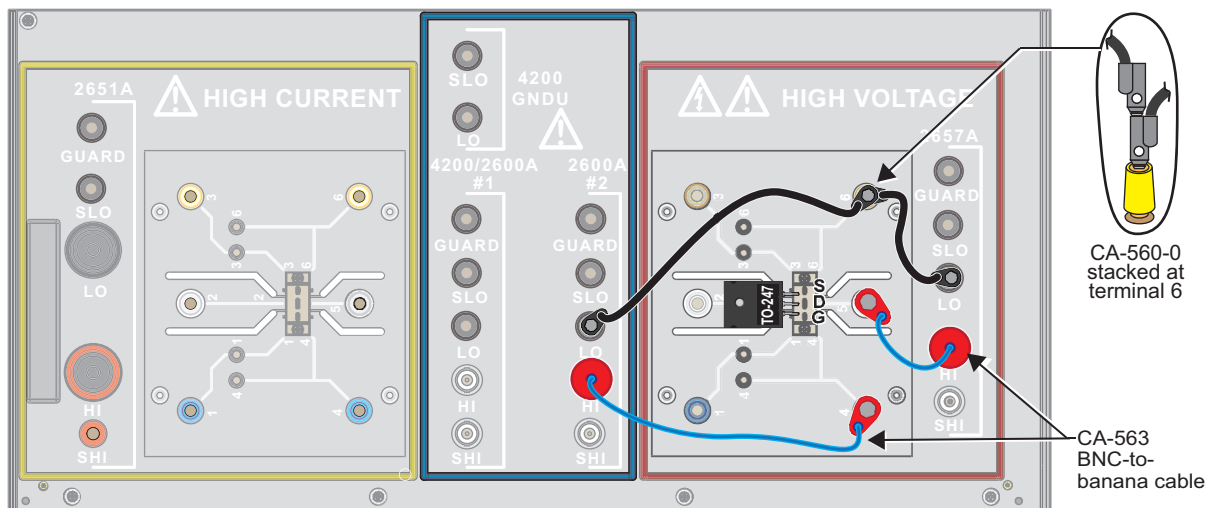

BV_{dss} measurement

NOTE

The example code is designed to be run from Test Script Builder or TSB Embedded. It can also be run from other programming environments, such as Microsoft® Visual Studio® or National Instruments LabVIEW™. However, you may need to make changes to the example code to use other programming environments.

This example performs the BV_{dss} measurement. The Model 2657A forces a current from the drain to source terminals and measures the resulting V_{ds} . This example uses a TSP script to perform the measurement. The script includes two separate functions for configuring the System SourceMeter Instrument and returning the raw current and voltage readings from the reading buffer.

The script is written using Test Script Processor (TSP) functions rather than as a single block of inline code. TSP functions are similar to functions in other programming languages, such as Microsoft® Visual C® or Visual Basic®. They must be called before the code in them is executed. Because of this, running the script alone will not execute the test. To execute the test, you need to run the script to load the functions into test script memory. You then call the functions.

Refer to the documentation for Test Script Builder or TSB Embedded for directions on how to run scripts and enter commands using the instrument console.

Example program code

```
--[[
  Title: FET Drain-Source Breakdown Voltage
  Description: This script measures the drain-source
  breakdown voltage (BVdss) of a FET.
--]]

--[[
  BVdss(gateV, drainI, measDelay, igLimit, vdLimit, numNPLC)

  Description: This function uses the Model 2657A to force a current
  from drain to source. The SMU also measures the resulting voltage (Vds)
  with the FET channel turned off. A second System SourceMeter Instrument
  applies the gate to source voltage (Vgs) to ensure that the gate is
  turned off.

  Parameters:
    gateV: Applied gate voltage (Vgs).
    drainI: Test current applied by the Model 2657A from
    drain to source (Id).
    measDelay: Measurement delay before making the drain voltage
    measurement (Vgs).
    igLimit: Current limit (compliance) for the SMU connected to the
    FET gate terminal.
    vdLimit: Voltage limit (compliance) for the SMU connected to the
    FET drain terminal.
    numNPLC: Integration time for the drain voltage measurement
    (in number of power line cycles).

  Example usage:
  BVdss(0, 0.001, 0.01, 0.01, 2000, 1)
--]]

function BVdss(gateV, drainI, measDelay, igLimit, vdLimit, numNPLC)

  --Initialize SMU.
  reset()
  errorqueue.clear()
  status.reset()
  tsplink.reset()

  --Configure source function.
  node[2].smua.source.func = node[2].smua.OUTPUT_DCVOLTS
  node[2].smua.source.levelv = gateV
  node[2].smua.source.limiti = igLimit

  smua.source.func = smua.OUTPUT_DCAMPS
  smua.source.rangei = drainI
  smua.source.leveli = drainI
  smua.source.limitv = vdLimit
```

```

--Configure measurement parameters.
smua.measure.rangev = vdLimit
smua.measure.nplc = numNPLC
smua.measure.delay = measDelay

--Run the test.
node[2].smua.source.output = 1
smua.source.output = 1

I,V = smua.measure.iv()

smua.source.output = 0
node[2].smua.source.output = 0

print("Test current:", I)
print("Measured voltage:", V)

end

```

Example program usage

The function in this script allows updates to the test parameters without rewriting or re-running the script. To run the test, call the `BVdss()` function, passing in the appropriate values for test parameters.

BV _{dss} () parameters		
Parameter	Units	Description
gateV	volts	Gate voltage to apply with Series 2600A System SourceMeter Instrument
drainI	amps	Drain current forced by Model 2657A
measDelay	seconds	Measurement delay after applying drain current and before measuring BV _{dss}
igLimit	amps	Current limit for the Series 2600A SourceMeter Instrument connected to the MOSFET gate terminal
vdLimit	volts	Voltage limit (compliance) for the Model 2657A connected to the MOSFET drain terminal; should be greater than or equal to the expected BV _{dss} value
numNPLC	not applicable	Integration time, specified as the number of power line cycles

An example of how to call this function is shown here:

```
BVdss(0, 0.001, 0.01, 0.01, 2000, 1)
```

This call applies 0 V to the FET gate terminal and programs the Model 2657A to force 1 mA into the drain terminal. After 10 ms, the drain voltage is measured (up to 2000 V max). The measurement is made at 1 PLC. The actual drain current is also measured. The measurement results are automatically printed at the completion of the test. An example of the measurements results is:

```

Test current:    9.99856e-04
Measured voltage: 1.76940e+03

```

Idss measurement

This example:

- Performs the I_{dss} measurement, where the drain-to-source voltage (V_{ds}) is swept and leakage current measurements are made while the FET is in the off-state.
- Monitors the current measurement to see if the current limit has been reached. When the current limit has been reached, the voltage sweep is aborted.

With this method, a second System SourceMeter is used to apply a voltage from gate to source (V_{gs}). This example uses a TSP script to perform the measurement. The script includes two separate functions for configuring the System SourceMeter Instruments and returning the raw current and voltage readings from the reading buffer.

Example program code

```
--[[
  Title: FET Drain-to-Source Leakage Current Measurement Sweep

  Description: This script measures the drain current while the
  drain voltage is sweeping linearly and under a 0 V gate bias.
--]]

--[[
  Idss(gateV, startV, stopV, numSteps, measDelay, measRange, iLimit, numNPLC)

  Description: This function uses the Model 2657A to sweep the voltage
  across the drain up to the drain-source breakdown voltage and measure
  the drain current. A second SourceMeter instrument is used to bias the
  gate. For enhancement-mode power MOSFETs, a typical gate bias is 0 V.

  Parameters:
    gateV: Applied gate voltage bias (Vgs).
    startV: Starting drain voltage (Vds).
    stopV: Final drain voltage (Vds).
    numSteps: Number of points in the drain voltage sweep.
    measDelay: Measurement delay.
    measRange: Current measurement range for the drain current measurements.
    iLimit: Current limit (compliance) for the drain current.
    numNPLC: Integration time in the number of power line cycles.

  Example Usage:
  Idss(0, 10, 1760, 500, 0.05, 100e-9, 500e-6, 1)
--]]
```

```
function Idss(gateV, startV, stopV, numSteps, measDelay, measRange, iLimit,
    numNPLC)

    --Initialize SMU.
    reset()
    errorqueue.clear()
    status.reset()

    --Configure reading buffers.
    smua.nvbuffer1.clear()
    smua.nvbuffer1.appendmode = 1
    smua.nvbuffer1.collecttimestamps = 1

    smua.nvbuffer2.clear()
    smua.nvbuffer2.appendmode = 1
    smua.nvbuffer2.collecttimestamps = 1

    --Configure source parameters for the gate SMU.
    node[2].smua.source.func = node[2].smua.OUTPUT_DCVOLTS
    node[2].smua.source.levelv = gateV
    node[2].smua.source.limiti = 0.001

    --Configure source parameters for the drain SMU.
    smua.source.func = smua.OUTPUT_DCVOLTS
    smua.source.levelv = 0
    smua.source.limiti = iLimit
    if math.abs(startV) > math.abs(stopV) then
        smua.source.rangev = startV
    else
        smua.source.rangev = stopV
    end

    --Configure measurement parameters for the drain SMU.
    smua.measure.rangei = measRange
    smua.measure.nplc = numNPLC
    smua.measure.delay = measDelay

    step = (stopV - startV)/(numSteps - 1)
    voltage = startV
    smua.source.levelv = voltage
```

```
--Run the test.
node[2].smua.source.output = 1
smua.source.output = 1
delay(1)

for i = 1, numSteps do
    smua.measure.iv(smua.nvbuffer1, smua.nvbuffer2);
    --Remove the following 4 lines if you do not want to monitor
    --for compliance
    testCmpl = smua.source.compliance
    if testCmpl == true then
        break
    end

    smua.source.levelv = voltage + step
    voltage = voltage + step
end

--Turn off the SMUs to complete the test.
smua.source.levelv = 0
node[2].smua.source.levelv = 0
node[2].smua.source.output = 0
smua.source.output = 0

printData()

end

function printData()

    if smua.nvbuffer1.n == 0 then
        print("No reading in buffer")
    else
        print("Timestamps\tVoltage\tCurrent")
        for i = 1, smua.nvbuffer1.n do
            print(string.format("%g\t%g\t%g", smua.nvbuffer1.timestamps[i],
                smua.nvbuffer2.readings[i], smua.nvbuffer1.readings[i]))
        end
    end
end

end
```

Example program usage

The functions in this script allow updates to the test parameters without rewriting or re-running the script. To run the test, call the `Idss()` function, passing in the appropriate values for test parameters.

Idss() parameters		
Parameter	Units	Description
gateV	volts	Gate voltage to apply with Series 2600A System SourceMeter Instrument
startV	volts	Start voltage for the drain voltage sweep
stopV	volts	Final voltage for the drain voltage sweep
numSteps	not applicable	Number of voltage steps to perform in the voltage sweep
measDelay	seconds	Measurement delay after applying drain voltage and before measuring drain leakage current
measRange	amps	Fixed current measurement range used to measure drain leakage current
iLimit	amps	Current limit (compliance) for the Model 2657A connected to the MOSFET drain terminal
numNPLC	not applicable	Integration time, specified as the number of power line cycles

An example of how to call this function is shown here:

```
Idss(0, 10, 1760, 500, 0.05, 100e-9, 500e-6, 1)
```

This call applies 0 V to the MOSFET gate terminal and programs the Model 2657A to generate a 500 point voltage sweep from 0 V to 1760 V at the drain terminal. After each voltage step, a 50 ms delay occurs before the current is measured. The measurement is made at 1 PLC. The measurements are stored in the instrument's reading buffers and are output from the communication interface immediately after the test is run.

Example output data is shown in the following graphic.

Figure 22: Example output data

Measurement of Idss vs. Drain Voltage

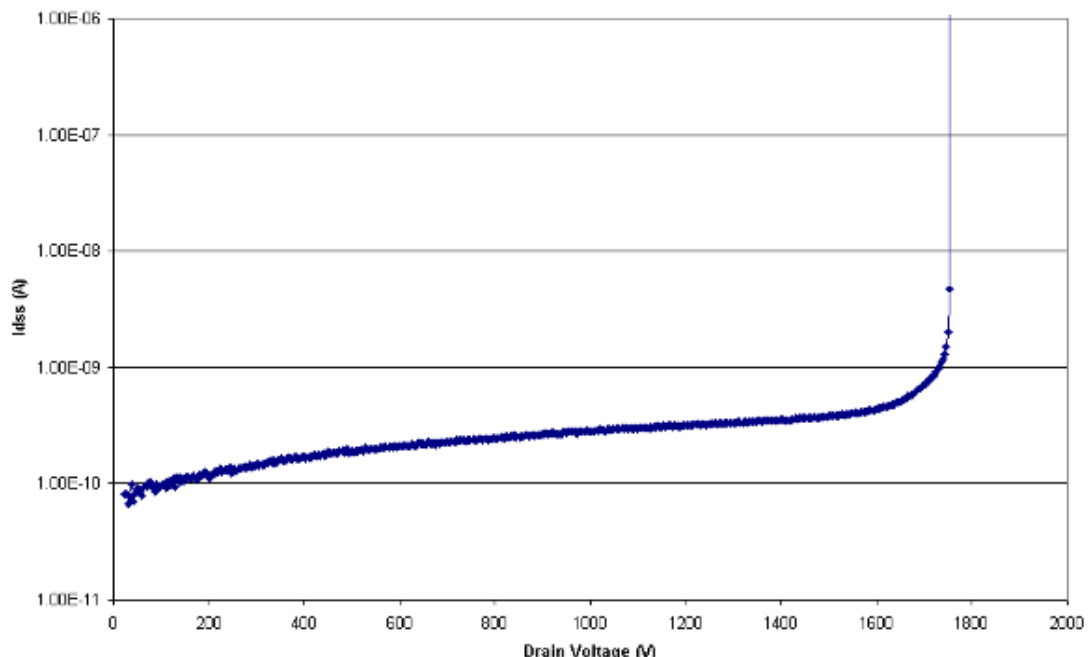

Axial-lead device high current test

In this section:

Introduction	5-1
Equipment needed	5-1
Connect the instrument to the Model 8010.....	5-2
Install the device and make connections.....	5-3
Set up communication.....	5-3
Example program code	5-4
Example program usage	5-9

Introduction

In this example, you will generate high speed current and voltage waveforms for a device with axial leads that is installed on the high current side of the Model 8010. This example illustrates how to connect to the device. It also demonstrates how to program the Model 2651A to output a pulse and generate high-speed current and voltage waveforms.

Equipment needed

Equipment required:

- One Model 8010 High Power Test Fixture with the Model 8010-DTB or Model 8010-DTB-220 board installed on the high current side of the test fixture (see [Installing the test boards](#) (on page 2-3) for more information)
- One Model 2651A High Power System SourceMeter instrument
- One device with axial leads, such as a resistor or diode
- Cables to connect the Model 2651A to the Model 8010: One Model 2651A-KIT-1, one Model CA-557-1
- Cables to connect instruments to the device in the Model 8010: One Model CA-560-0, one Model CA-562-0, one Model CA-562-2, and one Model 560-2 cable
- One GPIB cable or Ethernet cable

Connect the instrument to the Model 8010

Connect the Model 8010 to the Model 2651A as shown in the graphic below.

NOTE

This example does not use the interlock, although the connections for the interlock are shown in the following graphic. If you want to use the test fixture interlock and output enable, see the Model 2651A Reference Manual and the section "Using output enable."

Figure 23: Model 8010 to Model 2651A wiring diagram

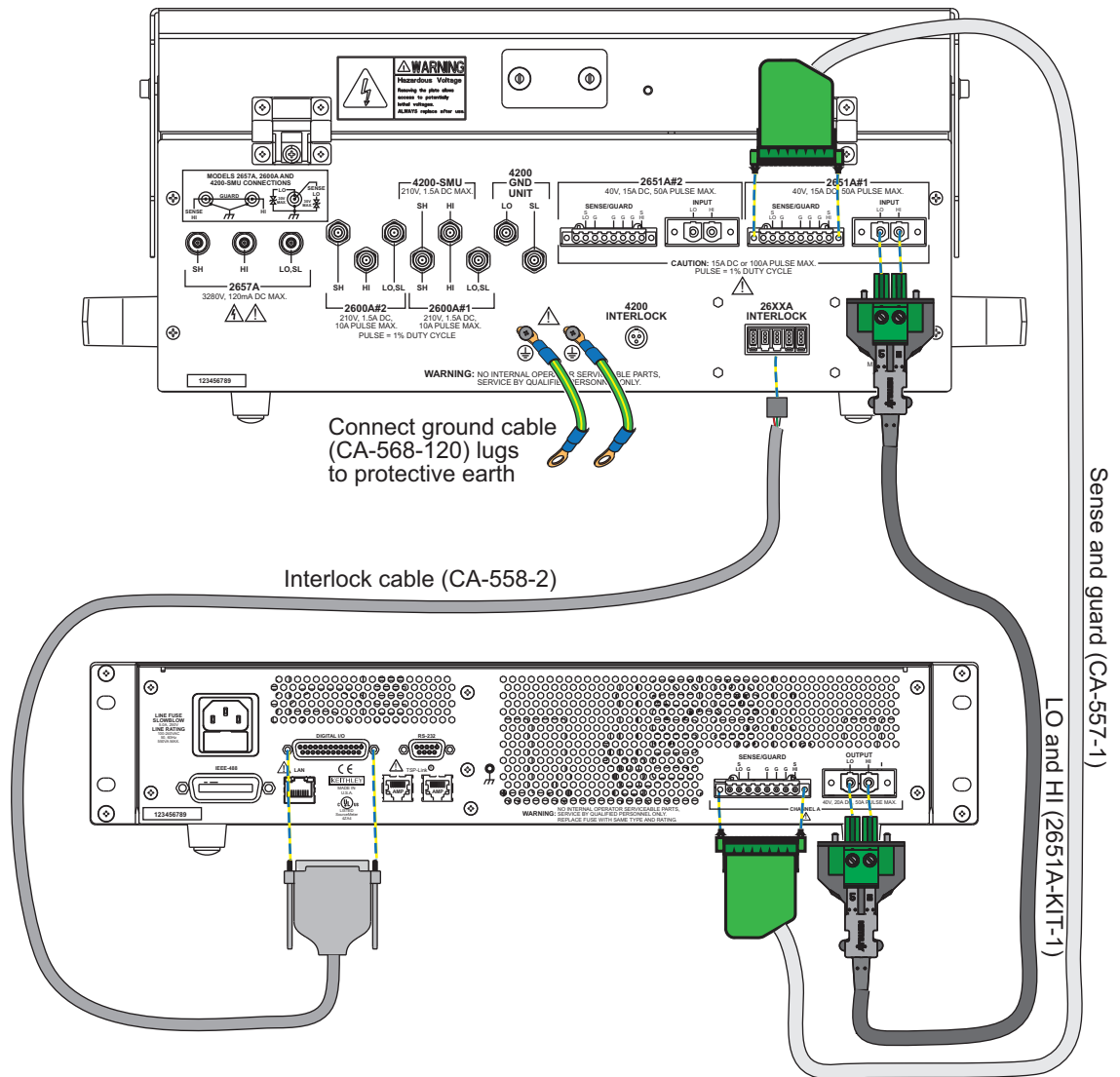

Install the device and make connections

To install a device in the Model 8010 and connect instruments to the device:

1. Ensure that the Model 8010-DTB or Model 8010-DTB-220 device test board is installed. Refer to [Installing the test boards](#) (on page 2-3) for information on installing the device test boards.
2. Install the device in the axial posts.
3. Insert the insulating plug in the 3-terminal socket. Refer to [Using the insulating plug](#) (on page 3-3) for more detail.
4. Make the connections as shown in the graphic below.

Figure 24: Two-terminal axial DUT with a Model 2651A connected (remote sense)

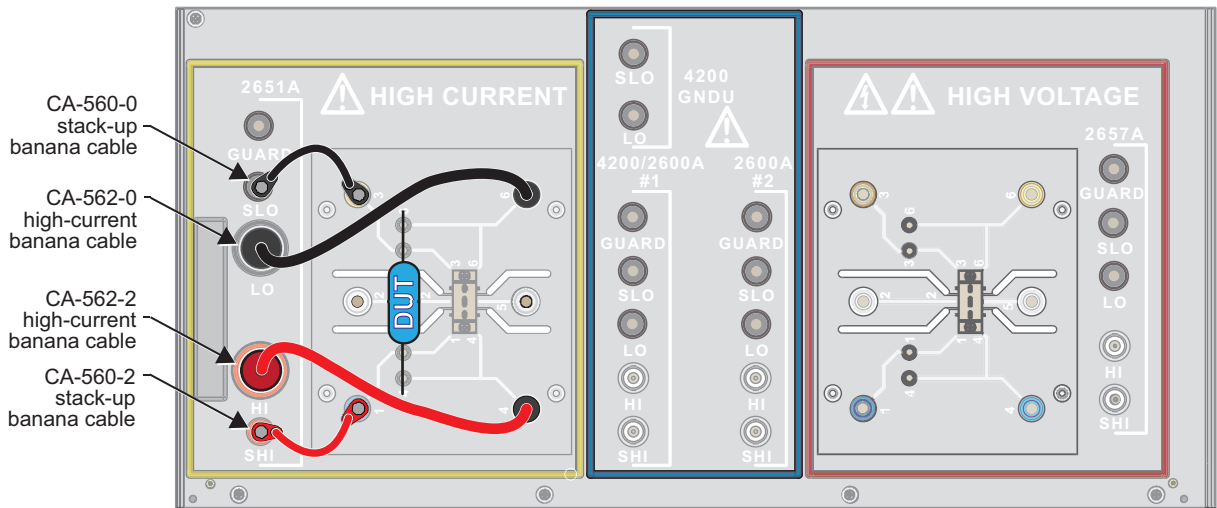

Set up communication

The communication setup is illustrated in the following figure. GPIB is used as an example, but this application can be run using any of the supported communication interfaces for the instrument.

Figure 25: GPIB communication example

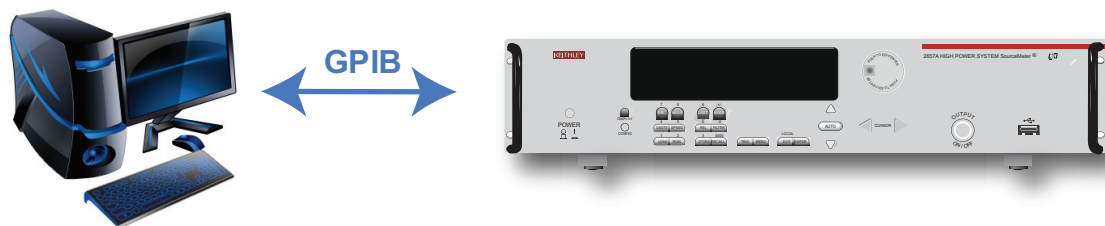

Example program code

NOTE

The example code is designed to be run from Test Script Builder or TSB Embedded. It can also be run from other programming environments, such as Microsoft® Visual Studio® or National Instruments LabVIEW™. However, you may need to make changes to the example code to use other programming environments.

The following script contains all the code necessary to output and capture a current or voltage pulse using the Model 2561A fast ADC. The script sets up the source-measure unit (SMU), configures the trigger model, prepares the reading buffers, executes the test, and outputs the collected data in a format that can be copied and pasted from the instrument console to a Microsoft® Excel® spreadsheet.

The script is written using Test Script Processor (TSP) functions rather than as a single block of inline code. TSP functions are similar to functions in other programming languages, such as Microsoft® Visual C® or Visual Basic®. They must be called before the code in them is executed. Because of this, running the script alone will not execute the test. To execute the test, you need to run the script to load the functions into test script memory. You then call the functions.

Refer to the documentation for Test Script Builder or TSB Embedded for directions on how to run scripts and enter commands using the instrument console.

The script contains comments that describe what is being performed by the lines of code and documentation for the functions in the script.

```
--[[
  Title: Fast ADC Usage
  Description: This script is designed to output pulses and capture
  both the current and the voltage of the pulse using the fast ADC of
  the Model 2651A High Power System SourceMeter instrument.

  Equipment Needed:
  1x 2651A
]]

--[[
  Name: CapturePulseV(pulseLevel, pulseWidth, pulseLimit, numPulses)
  Description:
  This function outputs voltage pulses with a 1% duty cycle and
  performs measurements using the fast ADC to capture each pulse in
  its entirety. At the conclusion of the pulse train, the data is
  returned to the instrument console in a Microsoft Excel compatible
  format.

  Parameters:
  pulseLevel: The voltage level of the pulse in volts
  pulseWidth: The width of the pulse in seconds
               100e-6 <= pulseWidth <= 4e-3
  pulseLimit: The current limit of the pulse in amps
  numPulses: The number of pulses to output

  Example Usage:
  CapturePulseV(5, 300e-6, 50, 5)
]]
```

```

function CapturePulseV(pulseLevel, pulseWidth, pulseLimit, numPulses)
  if (numPulses == nil) then numPulses = 1 end

  -- Configure the SMU
  reset()
  smua.reset()
  smua.source.func      = smua.OUTPUT_DCVOLTS
  smua.sense            = smua.SENSE_REMOTE
  smua.source.rangev   = pulseLevel
  smua.source.levelv   = 0      -- The bias level
  smua.source.limiti   = 5      -- The DC limit

  -- Use a measure range that is as large as the biggest
  -- possible pulse
  smua.measure.rangei  = pulseLimit
  smua.measure.rangev  = pulseLevel

  -- Select the fast ADC for measurements
  smua.measure.adc     = smua.ADC_FAST

  -- Set the measure count to be 1.25 times the width of the pulse
  -- to ensure we capture the entire pulse plus falling edge
  smua.measure.interval = 1e-6
  smua.measure.count    = (pulseWidth / smua.measure.interval) * 1.25

  -- Prepare the reading buffers
  smua.nvbuffer1.clear()
  smua.nvbuffer1.collecttimestamps = 1
  smua.nvbuffer1.collectsourcevalues = 0
  smua.nvbuffer1.fillmode          = smua.FILL_ONCE
  smua.nvbuffer2.clear()
  smua.nvbuffer2.collecttimestamps = 1
  smua.nvbuffer2.collectsourcevalues = 0
  smua.nvbuffer2.fillmode          = smua.FILL_ONCE
  -- Cannot use source values with async measurements

  -- Configure the Pulsed Sweep setup
  -----
  -- Timer 1 controls the pulse period
  trigger.timer[1].count      = numPulses - 1
  -- -- 1% Duty Cycle
  trigger.timer[1].delay      = pulseWidth / 0.01
  trigger.timer[1].passthrough = true
  trigger.timer[1].stimulus   = smua.trigger.ARMED_EVENT_ID

  -- Timer 2 controls the pulse width
  trigger.timer[2].count      = 1
  trigger.timer[2].delay      = pulseWidth - 3e-6
  trigger.timer[2].passthrough = false
  trigger.timer[2].stimulus   = smua.trigger.SOURCE_COMPLETE_EVENT_ID

```

```

-- Configure SMU Trigger Model for Sweep/Pulse Output
-----
-- Pulses will all be the same level so set start and stop to
-- the same value and the number of points in the sweep to 2
smua.trigger.source.linearv(pulseLevel, pulseLevel, 2)
smua.trigger.source.limiti      = pulseLimit
smua.trigger.measure.action     = smua.ASYNC
-- We want to start the measurements before the source action takes
-- place, so we must configure the ADC to operate asynchronously of
-- the rest of the SMU trigger model actions

-- Measure I and V during the pulse
smua.trigger.measure.iv(smua.nvbuffer1, smua.nvbuffer2)

-- Return the output to the bias level at the end of the pulse/sweep
smua.trigger.endpulse.action    = smua.SOURCE_IDLE
smua.trigger.endsweep.action    = smua.SOURCE_IDLE
smua.trigger.count              = numPulses
smua.trigger.arm.stimulus       = 0
smua.trigger.source.stimulus    = trigger.timer[1].EVENT_ID
smua.trigger.measure.stimulus   = trigger.timer[1].EVENT_ID
smua.trigger.endpulse.stimulus  = trigger.timer[2].EVENT_ID
smua.trigger.source.action      = smua.ENABLE

smua.source.output              = smua.OUTPUT_ON
smua.trigger.initiate()
waitcomplete()
smua.source.output              = smua.OUTPUT_OFF

PrintPulseData()
end

--[
Name:    CapturePulseI(pulseLevel, pulseWidth, pulseLimit,
                    numPulses)
Description:
    This function outputs current pulses with a 1% duty cycle and performs
    measurements using the fast ADC to capture each pulse in its entirety.
    At the conclusion of the pulse train, the data is returned to the
    instrument console in a Microsoft Excel compatible format.

Parameters:
    pulseLevel:    The current level of the pulse in amps
    pulseWidth:    The width of the pulse in seconds
                  100e-6 <= pulseWidth <= 4e-3
    pulseLimit:    The voltage limit of the pulse in volts
    numPulses:     The number of pulses to output

Example Usage:
    CapturePulseI(50, 300e-6, 10, 5)
]]

function CapturePulseI(pulseLevel, pulseWidth, pulseLimit, numPulses)
    if (numPulses == nil) then
        numPulses = 1
    end
end

```

```
-- Configure the SMU
reset()
smua.reset()
smua.source.func      = smua.OUTPUT_DCAMPS
smua.sense            = smua.SENSE_REMOTE
smua.source.rangei    = pulseLevel
smua.source.leveli   = 0    -- The bias level
smua.source.limitv    = 10  -- The DC limit
-- Use a measure range that is as large as the biggest possible pulse.
smua.measure.rangev   = pulseLimit
smua.measure.rangei   = pulseLevel

-- Select the fast ADC for measurements
smua.measure.adc      = smua.ADC_FAST

-- Set the measure count to be 1.25 times the width of the pulse
-- to ensure we capture the entire pulse plus falling edge
smua.measure.count    = (pulseWidth / smua.measure.interval) * 1.25

-- Prepare the reading buffers
smua.nvbuffer1.clear()
smua.nvbuffer1.collecttimestamps = 1
smua.nvbuffer1.collectsourcevalues = 0
smua.nvbuffer1.fillmode = smua.FILL_ONCE
smua.nvbuffer2.clear()
smua.nvbuffer2.collecttimestamps = 1
smua.nvbuffer2.collectsourcevalues = 0
smua.nvbuffer2.fillmode = smua.FILL_ONCE
-- Cannot use source values with async measurements

-- Configure the Pulsed Sweep setup
-----
-- Timer 1 controls the pulse period
trigger.timer[1].count = numPulses - 1
-- 1% Duty Cycle
trigger.timer[1].delay = pulseWidth / 0.01
trigger.timer[1].passthrough = true
trigger.timer[1].stimulus = smua.trigger.ARMED_EVENT_ID

-- Timer 2 controls the pulse width
trigger.timer[2].count = 1
trigger.timer[2].delay = pulseWidth - 3e-6
trigger.timer[2].passthrough = false
trigger.timer[2].stimulus = smua.trigger.SOURCE_COMPLETE_EVENT_ID
```

```

-- Configure SMU Trigger Model for Sweep/Pulse Output
-----
-- Pulses will all be the same level so set start and stop to
-- the same value and the number of points in the sweep to 2
smua.trigger.source.linear(pulseLevel, pulseLevel, 2)
smua.trigger.source.limitv      = pulseLimit
smua.trigger.measure.action     = smua.ASYNC
-- We want to start the measurements before the source action takes
-- place, so we must configure the ADC to operate asynchronously of
-- the rest of the SMU trigger model actions

-- Measure I and V during the pulse
smua.trigger.measure.iv(smua.nvbuffer1, smua.nvbuffer2)

-- Return the output to the bias level at the end of the pulse
smua.trigger.endpulse.action    = smua.SOURCE_IDLE
smua.trigger.endsweep.action    = smua.SOURCE_IDLE
smua.trigger.count              = numPulses
smua.trigger.arm.stimulus       = 0
smua.trigger.source.stimulus    = trigger.timer[1].EVENT_ID
smua.trigger.measure.stimulus   = trigger.timer[1].EVENT_ID
smua.trigger.endpulse.stimulus  = trigger.timer[2].EVENT_ID
smua.trigger.source.action      = smua.ENABLE

smua.source.output              = smua.OUTPUT_ON
smua.trigger.initiate()
waitcomplete()
smua.source.output              = smua.OUTPUT_OFF

PrintPulseData()
end

--[
  Name:   PrintPulseData()
  Description:
    This function prints the data contained in smua.nvbuffer1 and
    smua.nvbuffer2 in a format that is copy and paste compatible with
    Microsoft Excel.
]]

function PrintPulseData()
  print("Timestamp\tVoltage\tCurrent")
  for i=1, smua.nvbuffer1.n do
    print(string.format("%g\t%g\t%g", smua.nvbuffer1.timestamps[i],
      smua.nvbuffer2[i], smua.nvbuffer1[i]))
  end
end
end

```

Example program usage

The functions in this script allow the parameters of the test to be adjusted without rewriting and rerunning the script. To execute the test, either call `CapturePulseV()` to capture a voltage pulse or `CapturePulseI()` to capture current pulse, passing in the appropriate values as parameters. Both of these functions capture both current and voltage. The difference between the functions is what they are sourcing — one sources voltage, and the other sources current.

The parameters of the `CapturePulseV()` function are described in the following table:

CapturePulseV() parameters

Parameter	Units	Description
<code>pulseLevel</code>	Volts	The voltage level of the pulse
<code>pulseWidth</code>	Seconds	The width of the pulse
<code>pulseLimit</code>	Amperes	The current limit of the pulses to output
<code>numPulses</code>	Not applicable	The number of pulses to output

An example call to this function is as follows:

```
CapturePulseV(10, 300e-6, 50, 5)
```

This call will output five 10 V pulses with a 300 μ s pulse width. The pulses will be limited to 50 A and have a 1 percent duty cycle. At the completion of the pulsed outputs, the source-measure unit (SMU) output is turned off. The resulting data from this test will be returned in a Microsoft[®] Excel[®] compatible format (you can cut and paste the output from the console) that can be used for graphing and analysis.

The parameters of the `CapturePulseI()` function are contained in the following table:

CapturePulseI() parameters

Parameter	Units	Description
<code>pulseLevel</code>	Amperes	The current level of the pulse
<code>pulseWidth</code>	Seconds	The width of the pulse
<code>pulseLimit</code>	Volts	The voltage limit of the pulses to output
<code>numPulses</code>	Not applicable	The number of pulses to output

An example call to this function is as follows:

```
CapturePulseI(50, 300e-6, 10, 5)
```

This call will output five 50 A pulses with a 300 μ s pulse width. The pulses will be limited to 10 V and have a 1% duty cycle. At the completion of the pulsed outputs, the SMU output is turned off. The resulting data from this test will be returned in a Microsoft[®] Excel[®] compatible format (you can cut and paste the output from the console) that can be used for graphing and analysis.

Another example call to this function is as follows:

```
CapturePulseI(20, 1e-3, 10, 1)
```

This call will output one 20 A pulse with a 1 ms pulse width. The pulse will be limited to 10 V and have a 1% duty cycle. At the completion of the pulsed output, the SMU output is turned off. The resulting data from this test will be returned in a Microsoft® Excel® compatible format (you can cut and paste the output from the console) that can be used for graphing and analysis.

This data was generated with a 100 mΩ load.

Figure 26: Axial device test results

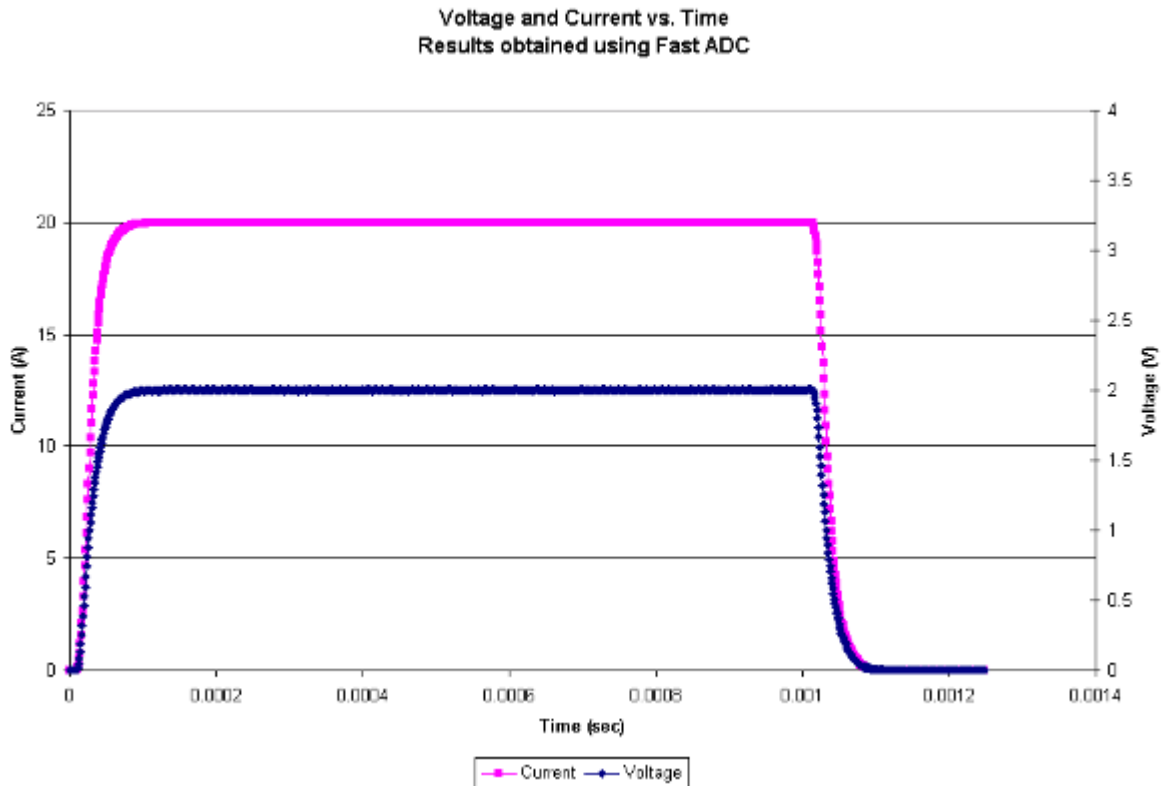

On-state characterization of a power MOSFET

In this section:

Introduction	6-1
Equipment required for this example.....	6-2
Connect instruments to the Model 8010.....	6-2
Install the device and make connections.....	6-6
Suppressing device oscillations (optional).....	6-7
Set up communication.....	6-8
Example program code	6-9
Example program usage	6-16

Introduction

This example illustrates how to connect to a MOSFET in a TO-247 package on the high current side of the Model 8010. It demonstrates how to program the two Model 2651A SourceMeter instruments and a Series 2600A instrument to measure the on resistance ($R_{ds(On)}$) of a power MOSFET and generate $R_{ds(On)}$ compared to drain current (I_d) curve for a fixed gate voltage.

The two Model 2651A instruments are used to supply the drain current and take measurements of drain voltage and drain current. The Series 2600A instrument is used to provide the gate voltage.

This example also provides detail on how to connect a resistor in series with the gate to suppress possible device oscillations.

Equipment required for this example

Equipment needed:

- One Model 8010 High Power Test Fixture with the Model 8010-DTB or Model 8010-DTB-220 board installed on the high current side of the test fixture (see [Installing the test boards](#) (on page 2-3) for more information)
- Two Model 2651A High Power System SourceMeter instruments
- One Series 2600A System SourceMeter instrument
- One power MOSFET in a TO-247 package
- Cables to connect the two Model 2651A instruments to the Model 8010: Two Model 2651A-KIT-1 and two Model CA-557-1 cable assemblies
- Cables to connect the Series 2600A to the Model 8010: Three Model 7078-TRX cable assemblies
- Adapter to connect the Series 2600A to the Model 8010: One Model 2600-TRIAx adapter for Models 2611A and 2612A
- Cables to connect instruments to the device in the Model 8010: One Model CA-562-2, one Model CA-562-0, three Model CA-560-0, one Model CA-560-2, and two Model 563 cables
- One CA-558-2 interlock cable
- One GPIB cable or Ethernet cable
- Two TSP-Link cables

Connect instruments to the Model 8010

Make connections between the Model 8010 and the SourceMeter Instruments as shown in the graphics below. Use the following graphic that is appropriate for your instrument.



WARNING

The ground wires must be attached to a known protective earth (safety ground) before powering on instruments. Failure to attach the ground wires to a known protective earth (safety ground) may result in electric shock.

Figure 27: Model 8010 to Model 2611A or 2612A rear panel connections for MOSFET application example

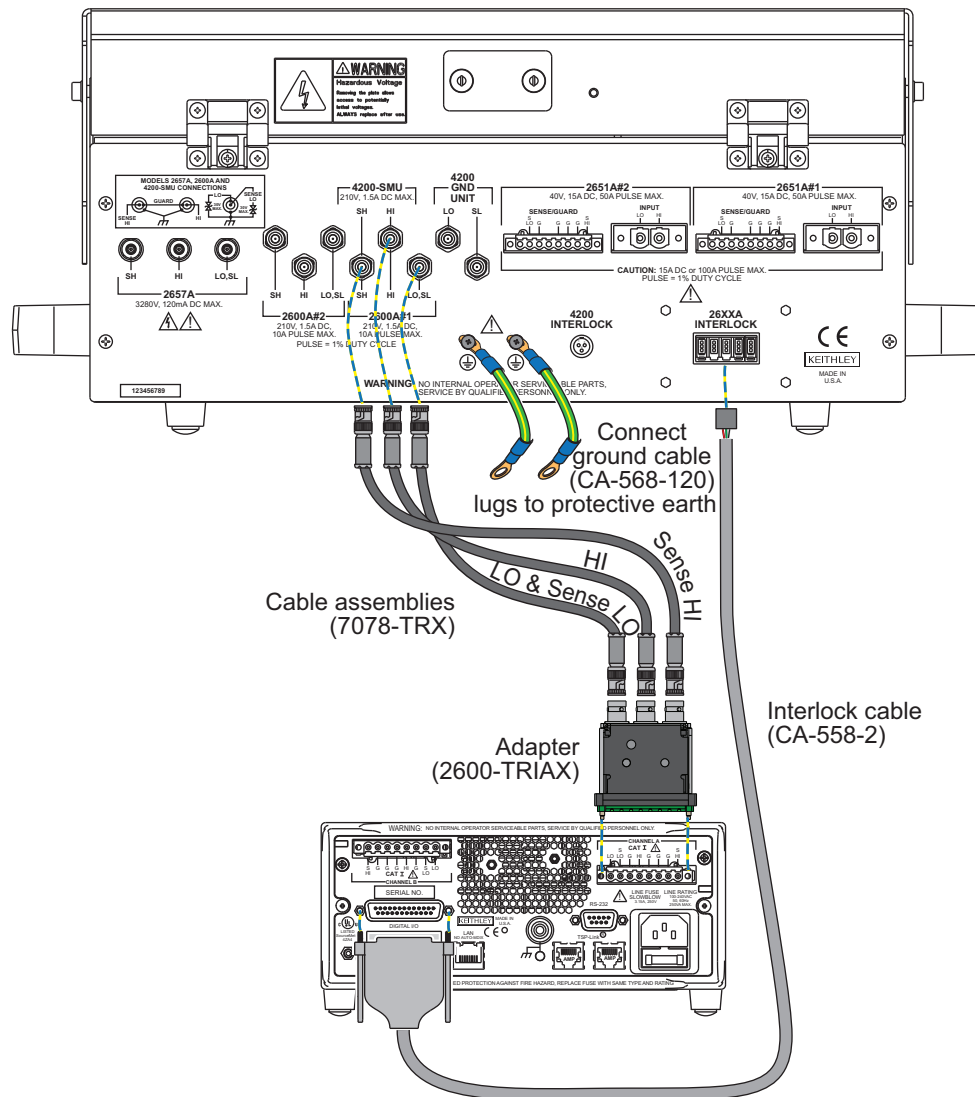
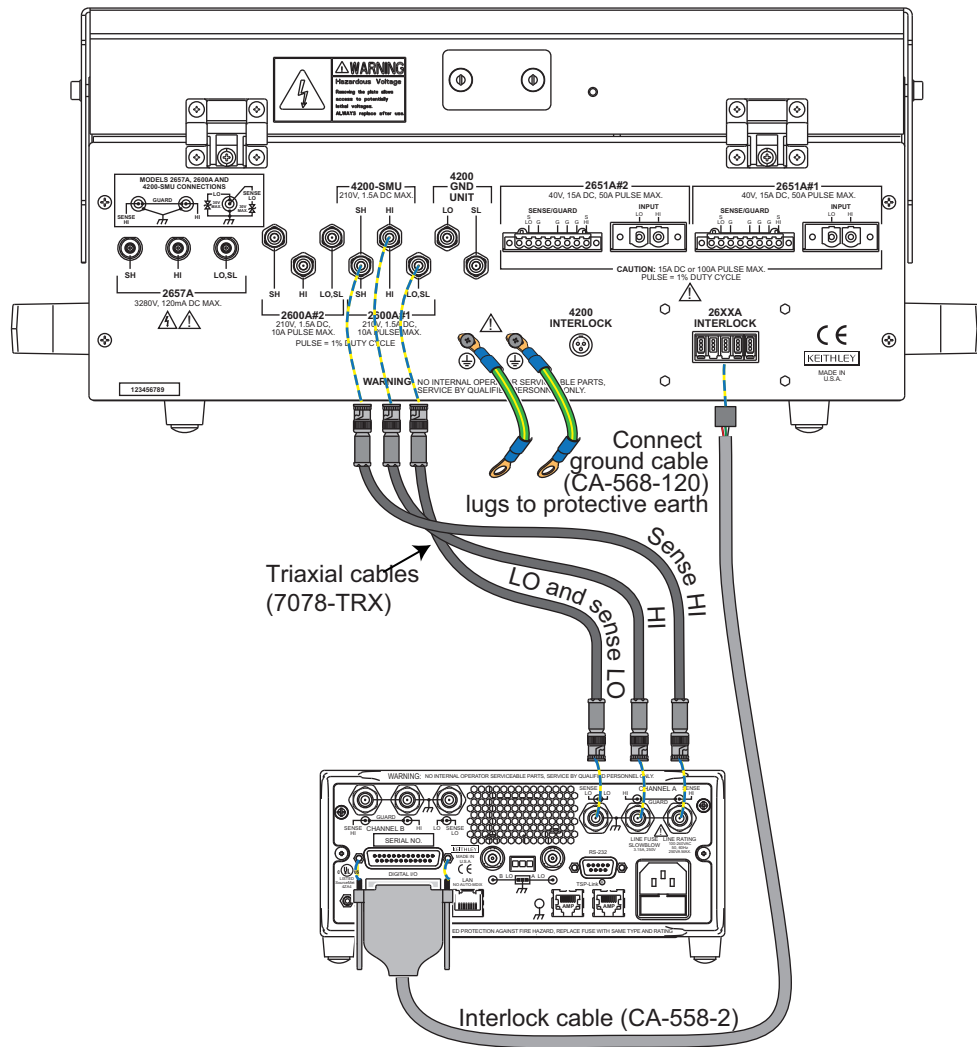

Figure 28: Model 8010 to Model 2635A or 2636A rear panel connections for MOSFET application example



NOTE

If you want to use the test fixture interlock and output enable, see the Model 2651A Reference Manual and the section "Using output enable."

Figure 29: Model 8010 to Model 2651A rear panel connections for the MOSFET application example

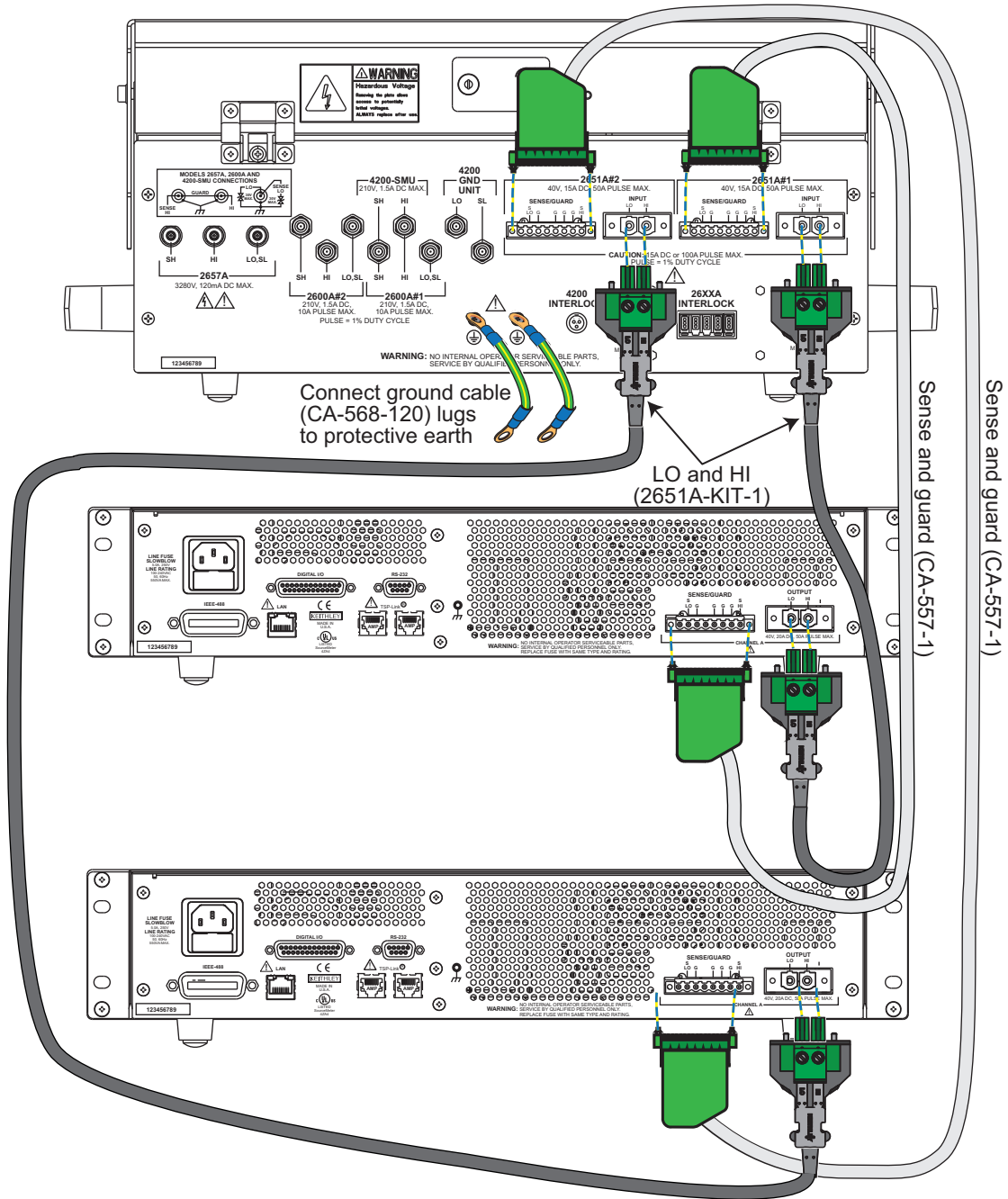

Install the device and make connections

To install a device in the Model 8010 and connect instruments to the device:

1. Ensure that the Model 8010-DTB or Model 8010-DTB-220 test board is installed. Refer to [Installing the test boards](#) (on page 2-3) for information on installing the device test boards.
2. Remove the insulating plug if installed.
3. Install the device in the socket so that the gate terminal is connected to pins 1 and 4 of the device test board.
4. Make the connections as shown in the graphic below.

Figure 30: Three-terminal DUT with one or two Model 2651A instruments and Series 2600A instrument connected (remote sense)

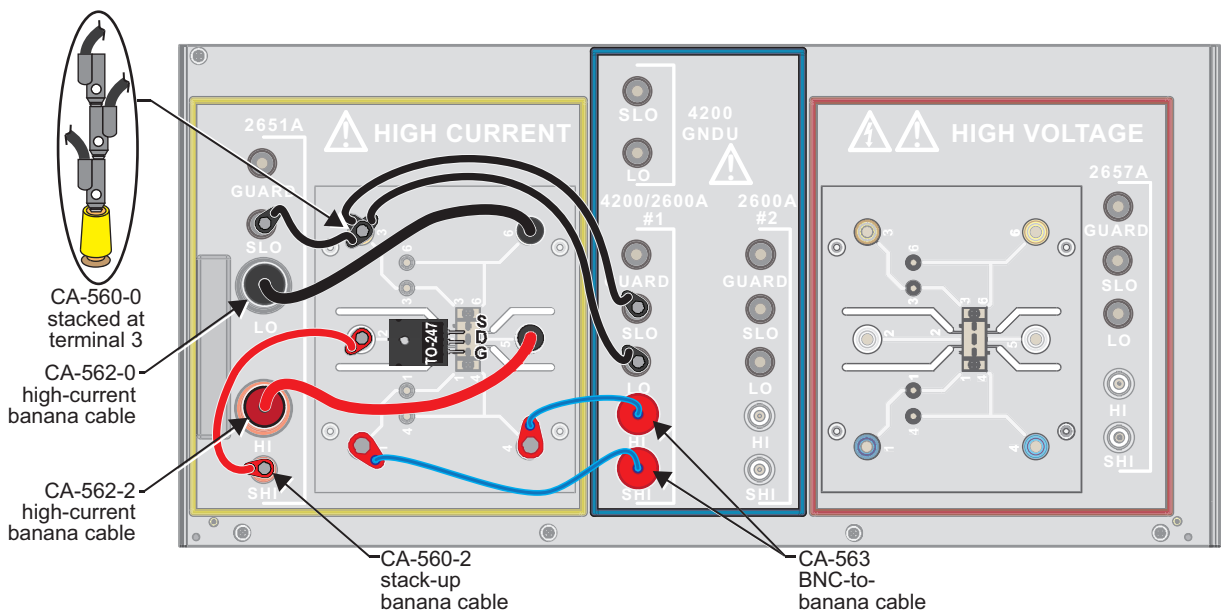

Suppressing device oscillations (optional)

Power transistors are prone to self-oscillation under forward bias conditions. In such cases, there may be oscillations or ringing in the gate or drain voltage waveforms. This would be visible using an oscilloscope or the high speed ADC of the Model 2651A when monitoring the drain waveform.

Some manufacturers recommend adding a resistor in series with the gate terminal to suppress these oscillations. The manufacturer may recommend a specific resistance value for this use or you may determine an appropriate resistance value by trial and error. Resistors are not supplied with the Model 8010, but customer-supplied leaded resistors may be easily installed in the Model 8010.

To add a series gate resistor in the Model 8010:

1. Loosen the binding post that is connected to pin 4 of the device test board.
2. Insert one end of the resistor into the opening at the base of the binding post.
3. Tighten the binding post to hold the resistor in place.
4. Remove the CA-563 cables that connect the Series 2600A HI and SHI terminals to pins 1 and 4 of the device test board.
5. Connect an alligator clip (customer-supplied) to the banana plug at the end of the SHI cable.
6. Connect the alligator clip to the other terminal of the axial resistor.
7. Stack the HI banana plug onto the SHI banana plug.

Figure 31: Three terminal DUT with a Model 2651A in remote with gate resistor installed

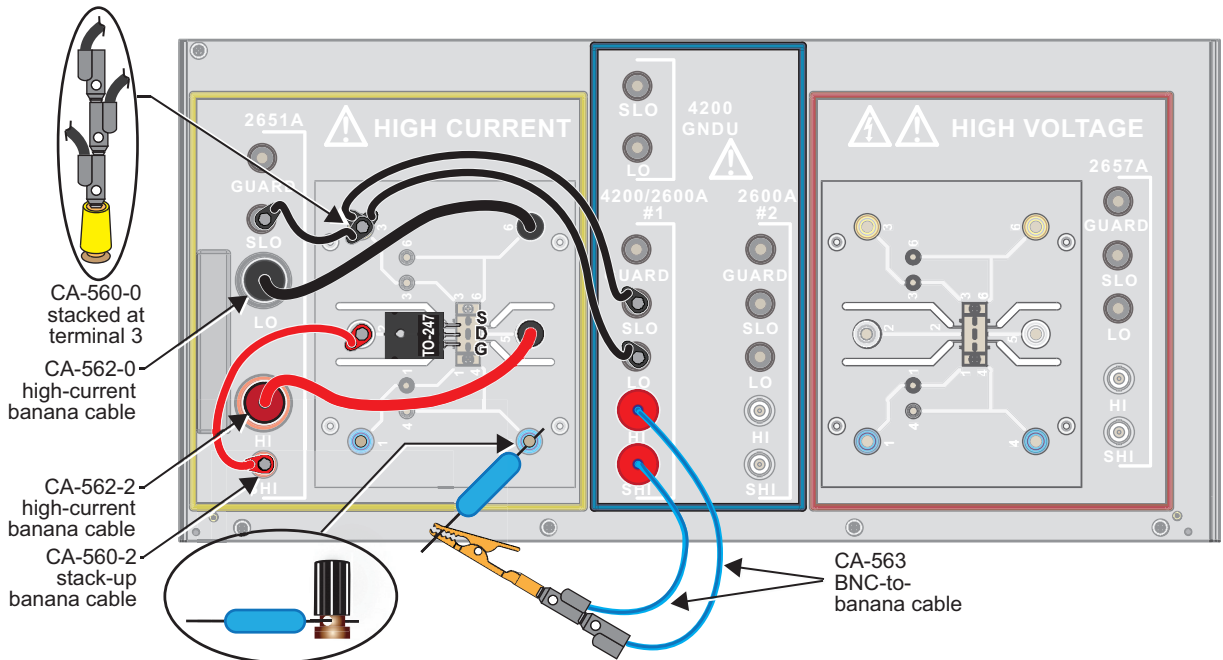

Set up communication

The communication setup is illustrated in the following diagram. GPIB is used as an example, but this application can be run using any of the supported communication interfaces for the instruments. A TSP-Link[®] connection enables communication between two instruments. Commands for the Model 2651A SMU #2 (node #2) and the Series 2600A SMU #3 (node #3) are sent over the TSP-Link interface.

Figure 32: GPIB communication example for Rds(on) sweep

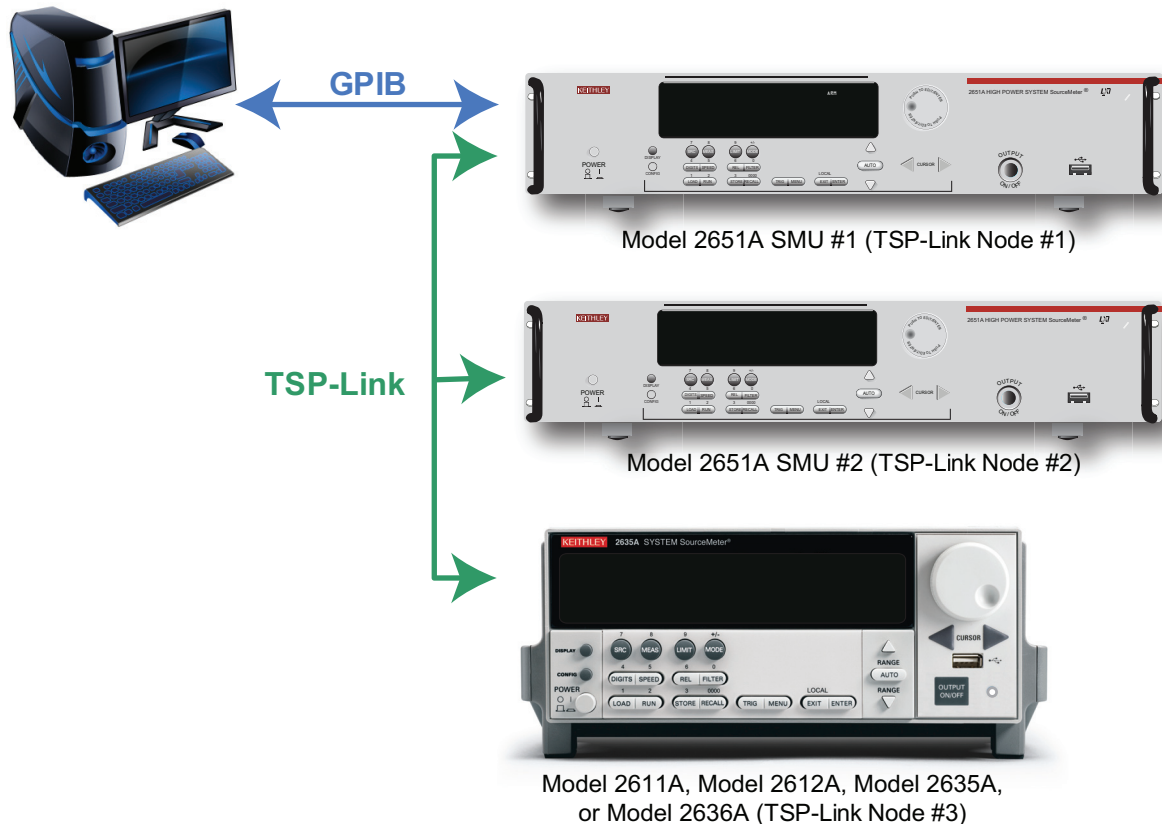

To set the TSP-Link node number using the front-panel interface:

1. Press the **MENU** key.
2. Select **TSPLink**.
3. Select **NODE**.
4. Use the navigation wheel  to adjust the node number.
5. Press the **ENTER** key to save the TSP-Link node number.

On the Model 2651A SMU #1 (TSP-Link node #1), perform a TSP-Link reset to update it with the linked instruments:

1. Press the **MENU** key.
2. Select **TSPLink**.
3. Select **RESET**.

NOTE

If error code 1205, "TSP-Link initialization failed (no remote nodes found)," is generated during the TSP-Link reset, ensure that each SourceMeter instrument has a unique TSP-Link node number.

Example program code**NOTE**

The example code is designed to be run from Test Script Builder or TSB Embedded. It can also be run from other programming environments, such as Microsoft® Visual Studio® or National Instruments LabVIEW™. However, you may need to make changes to the example code to use other programming environments.

The following script contains all the code necessary to perform an Rds(on) sweep up to 100 A using two Model 2651A High Power System SourceMeters and a Series 2600A System SourceMeter® Instrument. This script:

- Initializes the TSP-Link® connection
- Configures the source-measure units (SMUs)
- Configures the trigger models of the two Model 2651A instruments
- Prepares the reading buffers
- Executes the test
- Returns the collected data in a format that can be copied from the instrument console and pasted into a Microsoft® Excel® spreadsheet.

The script is written using Test Script Processor (TSP) functions rather than as a single block of inline code. TSP functions are similar to functions in other programming languages, such as Microsoft® Visual C® or Visual Basic®. They must be called before the code in them is executed. Because of this, running the script alone will not execute the test. To execute the test, you need to run the script to load the functions into test script memory. You then call the functions.

Refer to the documentation for Test Script Builder or TSB Embedded for directions on how to run scripts and enter commands using the instrument console.

The script contains comments. The comments describe what is being performed by the lines of code. They also document the functions in the script. Lines starting with `node[2]` . are commands that are being sent to the Model 2651A on node 2 through the TSP-Link interface. Lines starting with `node[3]` . are commands that are being sent to the Series 2600A through the TSP-Link interface. All other commands are executed on the master Model 2651A on `node [1]`.

```
--[[
Title:   Combining SMUs for 100A Example
Description: This script is designed to perform an Rds(on) sweep on a
power MOSFET device. It combines two 2651A SMUs in parallel to perform
a current sweep up to 100A. Data collected from the sweep is then
returned in a Microsoft Excel compatible format for plotting
and analysis.

Equipment needed:
    2x 2651A
    1x 26xxA
    2x TSP-Link Cable

TSP-Link Configuration:
-----
Unit          | Node #
2651A #1      | 1
2651A #2      | 2
26xxA         | 3

Master Node (PC Interface): Node 1
]]

--[[
Name:   DualSmuRdson(gateLevel, dstart, dstop, dsteps, pulseWidth,
pulsePeriod, pulseLimit)
Description: This function uses two 2651A SMUs to perform a pulsed Rds(on)
sweep with currents up to 100A.

Parameters:
    gateLevel:   The gate level to be used during the sweep
    dstart:      The starting current level of the drain sweep
    dstop:       The ending current level of the drain sweep
    dsteps:      The number of steps in the drain sweep
    pulseWidth:  The width of the drain pulse in seconds
    pulsePeriod: The time from the start of one drain pulse to
the next in seconds
    pulseLimit:  The voltage limit of the drain pulse in volts
    Note: Actual pulse limit will be 10% lower than setting
to protect SMUs in a compliance condition

Example Usage:
    DualSmuRdson(10, 1, 100, 100, 500e-6, 50e-3, 10)
]]
```

```

function DualSmuRdson(gateLevel, dstart, dstop, dsteps, pulseWidth, pulsePeriod,
    pulseLimit)
    tsplink.reset(3) -- Verify that at least three nodes are present
    reset()

    -- Configure 2651A #1 (Drain SMU 1)
    -----
    smua.reset()
    smua.source.func      = smua.OUTPUT_DCAMPS
    smua.sense            = smua.SENSE_REMOTE
    smua.source.offmode   = smua.OUTPUT_NORMAL
    smua.source.offfunc   = smua.OUTPUT_DCVOLTS
    smua.source.offlimiti = 1e-3 -- Set off limit

    -- SMU #1 will be a 0 V voltage source with 1mA limit when its
    -- output is turned off. SMU #2 will be a 0 A current source with
    -- a 10 V limit when the output is turned off. These settings keep
    -- the parallel combination safe in case one SMU is turned off.

    smua.source.rangei = math.max(math.abs(dstart / 2), math.abs(dstop / 2))
    smua.source.leveli  = 0 -- Sets the DC bias level
    smua.source.limitv  = 9 -- Sets the DC bias limit
    -- SMU #2 will have a voltage limit of 10V. By setting the voltage
    -- limit 10% lower than that of SMU #2, we can ensure that only
    -- one of the two SMUs will ever go into compliance and become a
    -- voltage source. This is desirable, because if both SMUs went
    -- into compliance, there would be two voltage sources in parallel,
    -- which is an unsafe condition.

    smua.measure.nplc   = 0.005
    smua.measure.rangev = pulseLimit
    smua.measure.autozero = smua.AUTOZERO_ONCE
    smua.measure.delay  =
        pulseWidth - ((1 / localnode.linefreq) * smua.measure.nplc) - 20e-6

    -- Set the delay so that the measurement is near the end of the pulse

    -- Prepare the reading buffers
    smua.nvbuffer1.clear()
    smua.nvbuffer1.collecttimestamps = 1
    smua.nvbuffer1.collectsourcevalues = 1
    smua.nvbuffer1.fillmode = smua.FILL_ONCE
    smua.nvbuffer2.clear()
    smua.nvbuffer2.collecttimestamps = 1
    smua.nvbuffer2.collectsourcevalues = 1
    smua.nvbuffer2.fillmode = smua.FILL_ONCE

    -- Configure TSP-Link Trigger 1
    tsplink.trigger[1].clear()
    tsplink.trigger[1].mode = tsplink.TRIG_FALLING
    tsplink.trigger[1].stimulus = trigger.timer[1].EVENT_ID
    -- TSP-Link Trigger 1 signals 2651A #2 to pulse

```

```

-- Timer 1 controls the pulse period by triggering the pulse to begin
trigger.timer[1].count          = dsteps - 1
trigger.timer[1].delay          = pulsePeriod
trigger.timer[1].passthrough    = true
trigger.timer[1].stimulus       = smua.trigger.ARMED_EVENT_ID
trigger.timer[1].clear()

-- Timer 2 controls the pulse width
trigger.timer[2].count          = 1
trigger.timer[2].delay          = pulseWidth - 3e-6
trigger.timer[2].passthrough    = false
trigger.timer[2].stimulus       = smua.trigger.SOURCE_COMPLETE_EVENT_ID
trigger.timer[2].clear()

-- Configure SMU Trigger Model for Sweep
-- Each unit will source half the current, so divide the start
-- and stop values by 2
smua.trigger.source.lineari(dstart / 2, dstop / 2, dsteps)
smua.trigger.source.limitv      = pulseLimit - (pulseLimit * 0.1)
-- Again, keep the limit SMU #1 lower than the limit of SMU #2
-- to prevent parallel V-sources
smua.trigger.measure.iv(smua.nvbuffer1, smua.nvbuffer2)
smua.trigger.measure.action     = smua.ENABLE

-- Return to the bias level at the end of the pulse/sweep
smua.trigger.endpulse.action    = smua.SOURCE_IDLE
smua.trigger.endsweep.action    = smua.SOURCE_IDLE

smua.trigger.count              = dsteps
smua.trigger.arm.stimulus       = 0
smua.trigger.source.stimulus    = trigger.timer[1].EVENT_ID
smua.trigger.measure.stimulus   = 0
smua.trigger.endpulse.stimulus  = trigger.timer[2].EVENT_ID
smua.trigger.source.action      = smua.ENABLE

-- Configure 2651A #2 (Drain SMU 2)
-----
node[2].smua.reset()
node[2].smua.source.func        = node[2].smua.OUTPUT_DCAMPS
node[2].smua.sense               = node[2].smua.SENSE_REMOTE
node[2].smua.source.offmode      = node[2].smua.OUTPUT_NORMAL
node[2].smua.source.offfunc      = node[2].smua.OUTPUT_DCAMPS
node[2].smua.source.offlimitv    = 10  -- Set off limit
-- SMU is a 0 A current source with 10 V limit when output is turned off
node[2].smua.source.rangei      =
    math.max(math.abs(dstart / 2), math.abs(dstop / 2))
node[2].smua.source.leveli       = 0  -- Sets the DC bias level
node[2].smua.source.limitv       = 10  -- Sets the DC bias limit
node[2].smua.measure.nplc        = 0.005
node[2].smua.measure.rangev      = pulseLimit
node[2].smua.measure.autozero    = node[2].smua.AUTOZERO_ONCE
node[2].smua.measure.delay       = (pulseWidth -
    ((1 / node[2].linefreq) * node[2].smua.measure.nplc)) - 20e-6
-- Set the delay so that the measurement is near the end of the pulse

```

```
-- Prepare the reading buffers
node[2].smua.nvbuffer1.clear()
node[2].smua.nvbuffer1.collecttimestamps      = 1
node[2].smua.nvbuffer1.collectsourcevalues    = 1
node[2].smua.nvbuffer1.fillmode               = node[2].smua.FILL_ONCE
node[2].smua.nvbuffer2.clear()
node[2].smua.nvbuffer2.collecttimestamps      = 1
node[2].smua.nvbuffer2.collectsourcevalues    = 1
node[2].smua.nvbuffer2.fillmode               = node[2].smua.FILL_ONCE

-- Configure TSP-Link Trigger 1
node[2].tsplink.trigger[1].clear()
node[2].tsplink.trigger[1].mode = node[2].tsplink.TRIG_FALLING

-- Timer 1 controls the pulse width
node[2].trigger.timer[1].count                = 1
node[2].trigger.timer[1].delay                 = pulseWidth - 3e-6
node[2].trigger.timer[1].passthrough           = false
node[2].trigger.timer[1].stimulus              =
    node[2].smua.trigger.SOURCE_COMPLETE_EVENT_ID
node[2].trigger.timer[1].clear()

-- Configure SMU Trigger Model for Sweep
node[2].smua.trigger.source.linear1(dstart / 2, dstop / 2, dsteps)
node[2].smua.trigger.source.limitv            = pulseLimit
node[2].smua.trigger.measure.iv(node[2].smua.nvbuffer1, node[2].smua.nvbuffer2)
node[2].smua.trigger.measure.action           = node[2].smua.ENABLE

-- Return the output to the bias level at the end of the pulse/sweep
node[2].smua.trigger.endpulse.action          = node[2].smua.SOURCE_IDLE
node[2].smua.trigger.endsweep.action          = node[2].smua.SOURCE_IDLE
node[2].smua.trigger.count                    = dsteps
node[2].smua.trigger.arm.stimulus             = 0
node[2].smua.trigger.source.stimulus          =
    node[2].tsplink.trigger[1].EVENT_ID
node[2].smua.trigger.measure.stimulus         = 0
node[2].smua.trigger.endpulse.stimulus        = node[2].trigger.timer[1].EVENT_ID
node[2].smua.trigger.source.action            = node[2].smua.ENABLE

-- Configure the 26xxA (Gate SMU)
-----
node[3].smua.reset()
node[3].smua.source.func                      = node[3].smua.OUTPUT_DCVOLTS
node[3].smua.sense                            = node[3].smua.SENSE_REMOTE
node[3].smua.source.levelv                    = gateLevel
node[3].smua.source.highc                     = node[3].smua.ENABLE
-- If you find your gate oscillating even with a dampening resistor
-- in place, try enabling the high capacitance mode to help
-- stabilize the gate.
```

```
-- Prepare the reading buffers
node[3].smua.nvbuffer1.clear()
node[3].smua.nvbuffer1.collectsourcevalues = 1
if node[3].smua.nvbuffer1.fillmode ~= nil then
    node[3].smua.nvbuffer1.fillmode = node[3].smua.FILL_ONCE
end
node[3].smua.nvbuffer2.clear()
node[3].smua.nvbuffer2.collectsourcevalues = 1
if node[3].smua.nvbuffer2.fillmode ~= nil then
    node[3].smua.nvbuffer2.fillmode = node[3].smua.FILL_ONCE
end

-----
-- Ready to begin the test
-----

-- Outputs on
node[3].smua.source.output = node[3].smua.OUTPUT_ON
node[2].smua.source.output = node[2].smua.OUTPUT_ON
smua.source.output = smua.OUTPUT_ON

if errorqueue.count > 0 then
    print("Errors were encountered")
    reset()
    return
end

-- Give the gate some time to settle before starting the sweep
delay(0.001)
node[3].smua.measure.iv(node[3].smua.nvbuffer1, node[3].smua.nvbuffer2)

-- Start the 2651A #2 trigger model
node[2].smua.trigger.initiate()
-- Start the 2651A #1 trigger model
smua.trigger.initiate()
-- Wait until test is complete
waitcomplete()

-- Outputs off
node[3].smua.source.output = node[3].smua.OUTPUT_OFF
smua.source.output = smua.OUTPUT_OFF
node[2].smua.source.output = node[2].smua.OUTPUT_OFF

-- Print back data
PrintDualSmuRdsonData()
end
```

```

--[[
Function:   PrintDualSmuRdsonData()
Description:
    This function processes the data stored in the SMU reading buffers by
    function DualSmuRdson() and prints back the individual SMU data and the
    combined SMU data and Rds(on) readings in a format that is copy and paste
    compatible with Microsoft Excel.
]]
function PrintDualSmuRdsonData()
    -- Print the gate SMU readings
    print("Gate SMU\r\nSource Value\tVoltage\tCurrent")
    print(string.format("%0.2f\t%g\t%g\r\n",
        node[3].smua.nvbuffer1.sourcevalues[1],
        node[3].smua.nvbuffer2[1],
        node[3].smua.nvbuffer1[1]))

    -- Print column headers
    print("Timestamp\tSource Value\tVoltage 1\tCurrent 1\tVoltage
        2\tCurrent 2\tVoltage\tCurrent\tRds(on)")
    -- Loop through the reading buffer printing one row at a time
    for i = 1,smua.nvbuffer1.n do
        -- Combined Source Level = SMU1 source level + SMU2 source level
        sourceLevel = smua.nvbuffer1.sourcevalues[i] +
            node[2].smua.nvbuffer1.sourcevalues[i]

        -- Combined Voltage = Average(SMU1 Voltage reading, SMU2 Voltage reading)
        combinedVoltage = (smua.nvbuffer2[i] + node[2].smua.nvbuffer2[i]) / 2

        -- Combined Current = SMU1 Current reading + SMU2 Current reading
        combinedCurrent = smua.nvbuffer1[i] + node[2].smua.nvbuffer1[i]

        -- Rds(on) = Combined Voltage / Combined Current
        rdson = combinedVoltage / combinedCurrent

        -- Print a row of data
        print(string.format("%g\t%g\t%g\t%g\t%g\t%g\t%g\t%g",
            smua.nvbuffer1.timestamps[i],
            sourceLevel,
            smua.nvbuffer2[i],
            smua.nvbuffer1[i],
            node[2].smua.nvbuffer2[i],
            node[2].smua.nvbuffer1[i],
            combinedVoltage,
            combinedCurrent,
            rdson))
    end
end
end

```

Example program usage

The functions in this script allow the sweep parameters of the test to be adjusted without having to rewrite and rerun the script. A test can be executed by calling the function `DualSmuRdson(gateLevel, dstart, dstop, dsteps, pulseWidth, pulsePeriod, pulseLimit)` with the appropriate values passed to it in its parameters.

DualSmuRdson() parameters

Parameter	Units	Description
<code>gateLevel</code>	Volts	The voltage level to hold the gate
<code>dstart</code>	Amperes	The level of the first step in the drain sweep
<code>dstop</code>	Amperes	The level of the last step in the drain sweep
<code>dsteps</code>	Not applicable	The number of steps in the drain sweep
<code>pulseWidth</code>	Seconds	The width of the pulse in the drain sweep
<code>pulsePeriod</code>	Seconds	The time between the start of consecutive pulses in the drain sweep
<code>pulseLimit</code>	Volts	The voltage limit of the pulses in the drain sweep

An example call to this function is as follows:

```
DualSmuRdson(10, 1, 100, 100, 500e-6, 50e-3, 10)
```

This call will set the gate source-measure unit (SMU) output to 10 V and then sweep the drain of the device from 1 A to 100 A in 100 points. The points of this sweep will be gathered using pulsed measurements with a pulse width of 500 μ s and a pulse period of 50 ms for a 1 percent duty cycle. These pulses will be limited to a maximum of 10 V. At the end of the sweep, all SMU outputs will be turned off. The resulting data from this test will be returned in a Microsoft[®] Excel[®] compatible format (you can cut and paste the output from the console) that can be used for graphing and analysis.

The data can be plotted to show drain current versus $R_{ds(on)}$ for the DUT. The following graphic is an example of this plot.

Figure 33: Example $R_{ds(on)}$ curves for a power MOSFET device

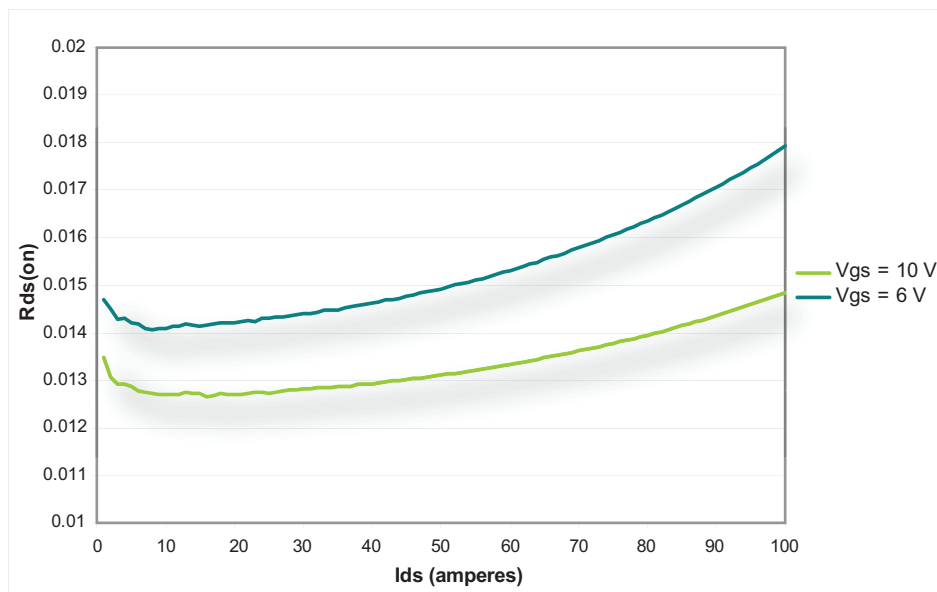

Troubleshooting FAQs

In this section:

Noisy low current measurements	7-1
Interlock error message	7-1
Can high-current SMUs be used separately inside the fixture?	7-1
The device is oscillating. How do I correct this?	7-2
Can I use local sense for high-current or lower power SMUs?	7-2
Can I operate the test fixture with the lid open?	7-2

Noisy low current measurements

I'm not getting the low current performance I expected. My current measurements are noisy. What is wrong?

Several factors can contribute to poor low current performance in the Model 8010 High Power Device Test Fixture.

The device test boards in the Model 8010 are not guarded. Therefore, the typical leakage current of the fixture is about 10 pA. These boards are subject to contamination, which will result in larger leakage currents. If you are using the boards for low leakage measurements, inspect and clean the device test boards regularly. See [How to clean the Model 8010 Test Fixture](#) (on page 8-1) for detail.

Interlock error message

The SourceMeter Instrument (SMU) output will not turn on and I get an error message about the interlock on the SMU front panel. What is wrong?

The lid of the Model 8010 test fixture contains a switch that controls the interlock of the Model 2657A and Series 2600A SourceMeter instruments. Closing the lid closes the switch and engages the interlock.

Make sure the interlock cables (part number CA-558-2) are properly connected between the instruments and the test fixture and that the lid of the test fixture is fully closed.

For additional information on interlocks, see [Using the interlock](#) (on page 2-5). Also see the reference manuals for your SMUs.

Can high-current SMUs be used separately inside the fixture?

No. The Model 8010 test fixture contains two connections for Model 2651A High Power SourceMeter instruments on its back panel. These two connections allow you to output up to a 100 A pulse using two instruments. Internally, these connectors are wired in parallel and are presented as a single output. This connection cannot be reconfigured.

The device is oscillating. How do I correct this?

During on-state characterization of MOSFET and IGBT devices, high-current pulses that travel through the channel of the device may cause the gate of the device to oscillate. The instability of the gate voltage will result in unstable measurements through the device channel.

To dampen these oscillations and stabilize the gate, you can insert a resistor between the gate of the device and the SourceMeter Instrument (SMU) connected to the gate. See [How to insert a resistor on a device terminal](#) (on page 3-6) for detail.

The appropriate gate resistor value is device-dependent. However, typical gate resistor values range from tens to hundreds of ohms.

If the gate remains unstable after inserting a dampening resistor, enable the high-capacitance mode (if available) on the SMU connected to the gate.

Can I use local sense for high-current or lower power SMUs?

Yes. All SMUs that are connected to the Model 8010 test fixture may be used in a two-wire (local sense) configuration.

NOTE

Four-wire remote sense is recommended when device resistances are low enough (less than 1 k Ω) that resistance in the test leads will cause significant error in the measurement. For more information, in the Series 2600A or Model 2651A Reference Manual, see "DUT test connections" for information on two-wire and four-wire sensing.

Can I operate the test fixture with the lid open?

The lid of the Model 8010 test fixture isolates the operator from hazardous voltages that are potentially present at the device under test and cable ports. The lid also functions as a blast shield, protecting the user from flying debris and fire.

The interlock circuitry of the Model 8010 test fixture is designed to be engaged only when the lid is closed. If the lid is open, the interlock is disengaged and any SourceMeter Instruments (SMUs) with outputs that are configured for high voltage will not turn on.

Low voltage SMUs may still operate with the lid open and without the interlock connected. For example, the Model 2651A will still operate if the output enable function is not activated. Additionally, the Models 2611A, 2612A, 2635A, 2636A, and 4200-SMU will operate if they are programmed to the 20 V range or lower.

For additional information on interlocks, see [Using the interlock](#) (on page 2-5). Also see the reference manuals for your SMUs.

WARNING

Always perform tests with the Model 8010 lid closed. Performing tests with the test fixture lid open may expose the user to electrical, burn, and projectile hazards.

Maintenance

In this section:

Replacing the boards	8-1
How to clean the Model 8010 Test Fixture	8-1
Connector and socket cleaning	8-2
Adjusting the lid hinges	8-2

Replacing the boards

The Model 8010 is shipped with two 8010-DTB Device Test Boards installed. The boards include connections for TO-247 and axial-lead devices.

The Model 8010 is also shipped with an 8010-CTB Customizable Test Board, which allows you to add your own connections.

In addition, you can purchase the 8010-DTB-220 Device Test Board for use with three-terminal TO-220 or TO-247 devices. This board is limited to 1000 V.

You can also purchase replacement 8010-DTB boards and 8010-CTB boards.

You can replace any of these boards as needed. For replacement instructions, see [Installing the test boards](#) (on page 2-3).

How to clean the Model 8010 Test Fixture

To prevent contamination that may degrade performance, use care when handling or servicing the test fixture.

To avoid damage to the test fixture, do not use any abrasive or chemical cleaning agents.

To clean the Model 8010:

1. Remove power from all instruments that are connected to the test fixture.
2. Remove loose dust on the outside and inside of the test fixture with a lint-free cloth.
3. Use a soft cloth or swab dampened with water to clean the test fixture. Use an aqueous solution of 75% isopropyl alcohol for more efficient cleaning. Avoid getting moisture inside the test fixture during cleaning. Use only enough cleaning solution to dampen the cloth or swab.

If a board becomes contaminated and operation is affected, the board should be returned to the factory for proper cleaning and servicing.

Connector and socket cleaning

The performance of connectors and sockets can degrade because of dirt build-up or improper handling. You can clean connectors and sockets with methanol-dipped cotton swabs.

After cleaning connectors and sockets, allow them to dry for at least one hour in a 50 °C low-humidity environment.

Adjusting the lid hinges

You can adjust the tension on the hinges on the lid of the Model 8010.

To adjust the tension, tighten or loosen the center screw on each hinge. See the following illustration for the screw location.

Figure 34: Model 8010 hinge adjustment

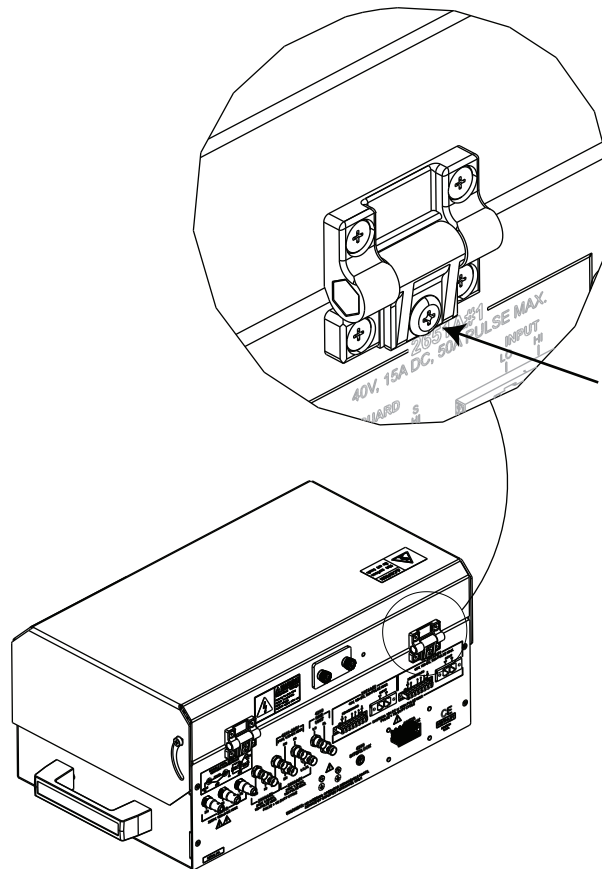

In this section:

[Additional information.....](#) 9-1

Additional information

This manual has prepared you to start using your new Model 8010 for your real-world applications.

For connection overviews, see the "Interconnection Reference Guide." It provides a quick reference for typical test connections. It also shows you how to install and set up the instrument. The "Interconnection Reference Guide" is provided with the test fixture and is also available as a PDF on the CD-ROMs that came with the test fixture.

For more detailed information about the SourceMeter instruments, refer to the SourceMeter instrument reference manuals.

The CD-ROMs that are included with your test fixture contain the following Model 8010 product document in PDF:

- The Interconnection Reference Guide
- This User's Manual
- Information for the TO-247 Device Test Board (8010-DTB), 8010-CTB Customizable Test Board (8010-CTB), and TO-220 or TO-247 Device Test Board (8010-DTB-220)
- The data sheet
- The product specifications

For additional support information, see <http://www.keithley.com/support> (<http://www.keithley.com>).

Index

A

access port • 2-12
accessories, available • 1-2
applications
 axial-lead device high current test • 5-1
 fast ADC • 5-1
 MOSFET characterization • 4-1
 power MOSFET characterize $R_{ds(on)}$ • 6-1
axial-lead device high current test • 5-1

B

board replacement • 8-1

C

characteristics • 1-3
cleaning
 connectors and sockets • 8-2
 test fixture • 8-1
connection • 3-2, 3-3
 rear panel • 2-1, 2-5
contact information • 1-2

E

error messages
 interlock • 7-1
examples
 Combining SMUs for 100 A current sweep • 6-9, 6-16
 fast-sampling ADC (examples) • 5-4

F

FAQs • 7-1

G

guard • 3-7

H

hinge adjustment • 8-2

I

installation
 device, axial posts • 3-2
 device, TO socket • 3-3
insulating plug • 3-3
interlock • 2-5, 7-1

L

low current measurements, improve • 7-1

M

maintenance • 8-1
measurement
 considerations • 3-3
MOSFET characterization • 4-1

O

oscillation
 suppress • 3-6, 7-2
oscilloscope probe • 2-12

P

poor low current performance • 7-1
port access • 2-12
protection circuitry • 2-12

R

rear panel
 access port • 2-12
 connection details • 2-5
 Model 2611A • 2-6
 Model 2612A • 2-6
 Model 2635A • 2-7
 Model 2636A • 2-7
 Model 2651A • 2-8
 Model 2657A • 2-9
 Model 4200 • 2-10, 2-11
 Model 4210-SMU • 2-10, 2-11
 summary • 2-1

S

safety information • 3-1
scripts
 Examples • 5-4, 5-9, 6-9, 6-16

T

test board
 about • 1-2, 3-1
 install device • 3-2, 3-3
 installation • 2-3
troubleshooting
 FAQs • 7-1

interlock error message • 7-1

W

Warranty • 1-2